



**SHEYENNE / WESTGO**

**1510**

**13"**

**Owner / Operator Manual  
& Parts Book**

701 Lenham Ave. - P.O. Box 647 – Cooperstown, ND 58425  
(701) 797-2700 – Fax (701) 797-2584 – [www.sheyennemfg.com](http://www.sheyennemfg.com)



This manual includes the following model, tube size and lengths - all with PTO main drive and the heavy scissor lift.

# 1510

## 13 Inch Dia

Lengths	Main Auger	Mech Drive Hopper – Std	Hyd Drive Hopper - Option
90'	PTO	X	Not Available
100'	PTO	X	Not Available

### Descriptions:

1510 - Auger model, with hanger bearings to support flighting

13" - Nominal auger diameter in inches

Lengths - Nominal auger length in feet

PTO - Power source - tractor power take off



## **ATTENTION DEALER**

**Be sure the OWNERS MANUAL remains with the auger when sold. It contains important procedures for safe operation of the auger.**



## SERIAL NUMBER LOCATION

Always give your dealer the serial number of your Sheyenne/Wesgo portable auger when ordering parts, requesting service or for information.

The serial number plate is located where indicated. Please mark this number and other information in the spaces provided. It will be useful for future reference.



Model Number \_\_\_\_\_

Serial Number \_\_\_\_\_

Production Year \_\_\_\_\_





Please enter information below and **SAVE FOR FUTURE REFERENCE**

## AUGER WARRANTY

SHEYENNE TOOLING & MANUFACTURING warrants each new product to be free from defects in material and workmanship. This warranty is applicable only for the normal service life expectancy of the machine or components, not to exceed **twelve consecutive months** from the date of delivery of the new SHEYENNE TOOLING & MANUFACTURING product to the original purchaser.

Genuine SHEYENNE TOOLING & MANUFACTURING replacement parts and components will be warranted for 90 days from date of purchase, or the remainder of the original equipment warranty period, whichever is longer.

Under no circumstances will it cover any merchandise or components thereof, which in the opinion of the company, has been subject to negligent handling, misuse, alteration, an accident, or if repairs have been made with parts other than those obtainable through SHEYENNE TOOLING & MANUFACTURING.

Our obligation under this warranty shall be limited to repairing or replacing, free of charge to the original purchaser, any part that in our judgment shall show evidence of such defect, provided further that such part shall be returned within thirty (30) days from date of failure to SHEYENNE TOOLING & MANUFACTURING.

This warranty shall not be interpreted to render us liable for injury or damages of any kind or nature to person or property.

Except as set forth above, **SHEYENNE TOOLING & MANUFACTURING shall have no obligation of liability of any kind on account of any of its equipment and shall not be liable for special or consequential damage. SHEYENNE TOOLING & MANUFACTURING makes no other warranty, express or implied, and, specifically, SHEYENNE TOOLING & MANUFACTURING disclaims any implied warranty of merchantability of fitness for a particular purpose. Some states or provinces do not permit limitations or exclusions of implied warranties of incidental or consequential damages, so the limitations or exclusions in this warranty may not apply.**

This warranty is subject to any existing conditions of supply, which may directly affect our ability to obtain materials or manufacture replacement parts.

SHEYENNE TOOLING & MANUFACTURING reserves the right to make improvements in design or changes in specifications at any time, without incurring any obligations to owners of units previously sold.

No one is authorized to alter, modify or enlarge neither this warranty nor the exclusions, limitations and reservations.

I have read and understand the above instructions and warranty. **Warranty is invalid until all three copies are completed and signed. Customer copy retained, dealer copy in dealer's possession and manufacturer's copy returned.**

---

Date Purchased _____	Dealership _____
Model Number _____	Serial Number _____
Customer Signature _____	Date _____
Dealer Signature _____	Date _____

**Customer Copy**

(Keep in this book)



Please enter information below and **SAVE FOR FUTURE REFERENCE**

## AUGER WARRANTY

SHEYENNE TOOLING & MANUFACTURING warrants each new product to be free from defects in material and workmanship. This warranty is applicable only for the normal service life expectancy of the machine or components, not to exceed **twelve consecutive months** from the date of delivery of the new SHEYENNE TOOLING & MANUFACTURING product to the original purchaser.

Genuine SHEYENNE TOOLING & MANUFACTURING replacement parts and components will be warranted for 90 days from date of purchase, or the remainder of the original equipment warranty period, whichever is longer.

Under no circumstances will it cover any merchandise or components thereof, which in the opinion of the company, has been subject to negligent handling, misuse, alteration, an accident, or if repairs have been made with parts other than those obtainable through SHEYENNE TOOLING & MANUFACTURING.

Our obligation under this warranty shall be limited to repairing or replacing, free of charge to the original purchaser, any part that in our judgment shall show evidence of such defect, provided further that such part shall be returned within thirty (30) days from date of failure to SHEYENNE TOOLING & MANUFACTURING.

This warranty shall not be interpreted to render us liable for injury or damages of any kind or nature to person or property.

Except as set forth above, **SHEYENNE TOOLING & MANUFACTURING shall have no obligation of liability of any kind on account of any of its equipment and shall not be liable for special or consequential damage. SHEYENNE TOOLING & MANUFACTURING makes no other warranty, express or implied, and, specifically, SHEYENNE TOOLING & MANUFACTURING disclaims any implied warranty of merchantability of fitness for a particular purpose. Some states or provinces do not permit limitations or exclusions of implied warranties of incidental or consequential damages, so the limitations or exclusions in this warranty may not apply.**

This warranty is subject to any existing conditions of supply, which may directly affect our ability to obtain materials or manufacture replacement parts.

SHEYENNE TOOLING & MANUFACTURING reserves the right to make improvements in design or changes in specifications at any time, without incurring any obligations to owners of units previously sold.

No one is authorized to alter, modify or enlarge neither this warranty nor the exclusions, limitations and reservations.

I have read and understand the above instructions and warranty. **Warranty is invalid until all three copies are completed and signed. Customer copy retained, dealer copy in dealer's possession and manufacturer's copy returned.**

---

Date Purchased \_\_\_\_\_

Dealership \_\_\_\_\_

Model Number \_\_\_\_\_

Serial Number \_\_\_\_\_

Customer Signature \_\_\_\_\_

Date \_\_\_\_\_

Dealer Signature \_\_\_\_\_

Date \_\_\_\_\_

**Dealer Copy**





Manufacturer Copy

PLEASE ENTER INFORMATION BELOW AND RETURN TO SHEYENNE TOOLING AND MANUFACTURING

### AUGER WARRANTY

SHEYENNE TOOLING & MANUFACTURING warrants each new product to be free from defects in material and workmanship. This warranty is applicable only for the normal service life expectancy of the machine or components, not to exceed twelve consecutive months from the date of delivery of the new SHEYENNE TOOLING & MANUFACTURING product to the original purchaser.

Genuine SHEYENNE TOOLING & MANUFACTURING replacement parts and components will be warranted for 90 days from date of purchase, or the remainder of the original equipment warranty period, whichever is longer. Warranty is not applicable for normal wear and usage.

Under no circumstances will it cover any merchandise or components thereof, which in the opinion of the company, has been subject to negligent handling, misuse, alteration, an accident, or if repairs have been made with parts other than those obtainable through SHEYENNE TOOLING & MANUFACTURING.

Our obligation under this warranty shall be limited to repairing or replacing, free of charge to the original purchaser, any part that in our judgement shall show evidence of such defect, provided further that such part shall be returned within thirty (30) days from date of failure to SHEYENNE TOOLING & MANUFACTURING.

This warranty shall not be interpreted to render us liable for injury or damages of any kind or nature to person or property.

Except as set forth above, SHEYENNE TOOLING & MANUFACTURING shall have no obligation of liability of any kind on account of any of its equipment and shall not be liable for special or consequential damage. SHEYENNE TOOLING & MANUFACTURING makes no other warranty, express or implied, and, specifically, SHEYENNE TOOLING & MANUFACTURING disclaims any implied warranty of merchantability of fitness for a particular purpose. Some states or provinces do not permit limitations or exclusions of implied warranties of incidental or consequential damages, so the limitations or exclusions in this warranty may not apply.

This warranty is subject to any existing conditions of supply, which may directly affect our ability to obtain materials or manufacture replacement parts.

SHEYENNE TOOLING & MANUFACTURING reserves the right to make improvements in design or changes in specifications at any time, without incurring any obligations to owners of units previously sold.

No one is authorized to alter, modify or enlarge neither this warranty nor the exclusions, limitations and reservations.

I have read and understand the above instructions and warranty. I have also read the owner's manual and understand all safety precautions. **Warranty is invalid until all three copies are completed and signed. Customer copy retained, dealer copy in the dealer's possession and the manufacturer's copy returned.**

Date Purchased \_\_\_\_\_ Dealership \_\_\_\_\_

Model Number \_\_\_\_\_ Serial Number \_\_\_\_\_

Customer Information: Name (Please Print) \_\_\_\_\_

Address \_\_\_\_\_

City \_\_\_\_\_, State \_\_\_\_\_, Zip Code \_\_\_\_\_

E-Mail (If Applicable) \_\_\_\_\_

Signature \_\_\_\_\_, Date \_\_\_\_\_

Dealer Signature \_\_\_\_\_ Date \_\_\_\_\_

Please return via; fax, regular mail or e-mail; to:
fax number - (701) 797-2584
address --
Sheyenne Tooling and Manufacturing
PO Box 647
Cooperstown, ND 58425
e-mail - warranty@sheyennemfg.com



## TABLE OF CONTENTS

<u>DESCRIPTION</u>	<u>PAGE</u>
Augers in this manual .....	1
Dealer information .....	2
Serial number location .....	3
Warranty pages .....	-
Table of contents .....	4
Introduction .....	5
Safety symbols .....	6
Safety reasons .....	7
General safety .....	8 – 13
Safety sign-off form .....	14
Safety decal locations .....	15 – 17
Safety review and training .....	18
Machine components .....	19
Break-in procedures .....	20
Hook-up .....	21 & 22
Machine placement / Hopper lift operation .....	23 & 24
Operation .....	25 – 27
Transporting / Operation .....	28 - 30
Storage .....	31
Servicing .....	32 – 34
Service record .....	35
Maintenance .....	36 – 40
Hopper mounting option / left or right .....	41
Hanger bearing replacement / Timing .....	42
Timing the flighting .....	43
Trouble shooting .....	44
Mechanical specifications .....	45
Lift dimensions and axle width dimensions .....	46
Bolt torque specifications .....	47
Note page (for your use) .....	48
Parts - Table of contents .....	49





## 1 INTRODUCTION

Congratulations on your choice of a Sheyenne/Westgo Portable Auger to compliment your farming operation. This equipment has been designed and manufactured to meet the needs of the discerning farmer for the efficient moving of grain.

Safe, efficient and trouble free operation of your Portable Auger requires that you and anyone else who will be operating or maintaining the Auger, read and understand the Safety, Operation, Maintenance and Trouble Shooting information contained within the Operator's Manual.



### **1510 13 x 90, PTO DRIVE w/ MECHANICAL DRIVE HOPPER and DOUBLE POWER WHEEL**

This manual covers the Model 1510 auger made by Sheyenne/Westgo. Available in lengths of 90' and 100'. All with PTO drive and new design 1510 transport, hopper, incline tube and pivot drive.

Keep this manual handy for frequent reference and to pass on to new operators or owners. Call your Sheyenne/Westgo dealer if you need assistance, information or additional copies of this manual.

**AUGER ORIENTATION** - The directions left, right, front and rear, as mentioned throughout the manual, are seen from the tractor driver's seat and facing in the direction of travel when the unit is being transported. The front is the intake end of the auger, rear is the spout.

A simple comparison is that of a semi tractor-trailer rig. The right side "runs" from back bumper to the front bumper of the rig, even though the driver is seated quite far forward. If the driver turns around and looks backward, that doesn't change the right and left trailer wheels. The same is true of the auger.



**THE SYMBOL SHOWN BELOW IS USED TO  
CALL YOUR ATTENTION TO INSTRUCTIONS  
CONCERNING YOUR PERSONAL SAFETY**



**BE ALERT!**

**Your Safety is involved**



## 2 SAFETY

### SAFETY ALERT SYMBOL



Why is **SAFETY** so important to you?

#### 3 Big Reasons

**Accidents Disable and Kill**

**Accidents Are Costly**

**Accidents Can Be Avoided**

This safety alert symbol appears in this manual and on many of the decals on the auger. It is used to draw your attention to the possibility of personal injury or loss of life. We **urge** you to follow all safety instructions. Be alert to safety issues at **all** times!

In addition you will see the use of **signal words** with the safety messages. The appropriate signal word for each message has been selected using the following guide-lines:

**DANGER** – An immediate and specific hazard which **will** result is severe personal injury or death if the proper precautions are not taken.

**WARNING** – A specific hazard or unsafe practice which **could** result in severe personal injury or death if proper precautions are not taken.

**CAUTION** – Unsafe practices which **could** result in personal injury if proper practices are not taken, or as a reminder of good safety practices.

## 2 SAFETY

YOU are responsible for the safe operation and maintenance of your Sheyenne/Westgo Portable Auger. YOU must ensure that you and anyone else who is going to operate, maintain or work around the Auger be familiar with the operating and maintenance procedures and related Safety information contained in this manual. This manual will take you step -by- step through your working days and alerts you to all good safety practices that should be adhered to while operating the Auger.

Remember, YOU are the key to safety. Good safety practices not only protect you but also the people around you. Make these practices a working part of your safety program. Be certain that EVERYONE operating this equipment is familiar with the recommended operating and maintenance procedures and follows all the safety precautions. Most accidents can be prevented. Do not risk injury or death by ignoring good safety practices.

\* Auger owners must give operating instructions to operators or employees before allowing them to operate the Auger, and at least annually thereafter per OSHA (Occupational Safety and Health Administration) regulation 1928.57.

\* The most important safety device on this equipment is a safe operator. It is the operators responsibility to read and understand All Safety and Operating instructions in the manual and to follow them. All accidents can be avoided.

\* A person who has not read and understood all operating and safety instructions is not qualified to operate the machine. An untrained operator exposes himself and bystanders to possible serious injury or death.

\* Do not modify the equipment in any way. Unauthorized modification may impair the function and/or safety and could affect the life of the equipment.

### 2.1 GENERAL SAFETY

1. Read and understand the Operator's Manual before operating, maintaining or adjusting the Auger.



2. Only trained competent persons shall operate the Auger. An untrained operator is not qualified to operate this machine.

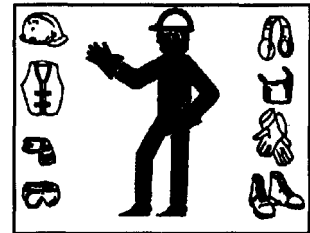
3. Have a first-aid kit available for use should the need arise and know how to use it.



4. Do not allow children, spectators or bystanders within hazard area of machine.

5. Wear appropriate protective gear. This list includes but is not limited to:

- A hard hat,
- Protective shoes with slip resistant soles
- Protective goggles
- Heavy gloves
- Hearing protection
- Respirator or filter mask



6. Stop the engine, place all controls in neutral, set park brake, remove ignition key and wait for all moving parts to stop before servicing, adjusting, repairing, or unplugging.

7. Review safety related items annually with all personnel who will be operating or maintaining the Auger.

8. Have another person nearby who can shut down the auger in case of an accident. It is good practice to always work with a second person around augers.

Work Safely !

Think SAFETY !

## 2.2 OPERATING SAFETY

1. Read and understand the Operator's Manual and all safety signs before using.
2. Stop the tractor engine, place all controls in neutral, set park brake, remove ignition key and wait for all moving parts to stop before servicing, adjusting, repairing or unplugging.
3. Clear the area of all bystanders, especially children, before starting.
4. Be familiar with machine hazard area. If anyone enters hazard area, shut down machine immediately. Clear the area before restarting.
5. Keep hands, feet, hair and clothing away from all moving and/or rotating parts.
6. Do not allow riders on the Auger or tractor when transporting.
7. Stay away from overhead obstructions and power lines during operation and transporting. Electrocutation can occur without direct contact.
8. Do not operate machine when any guards are removed.
9. Set park brake on tractor before starting.
10. Lower Auger to its lowest position when transporting or when not in use.
11. Have another person nearby who can shut down the auger in case of an accident. It is good practice to always work with a second person around augers.
12. Inspect lift cable before using auger. Replace if frayed or damaged.
13. Make certain the lift cable is properly seated in cable pulleys.
14. Ensure that auger is empty before raising or lowering.

## 2.3 PLACEMENT SAFETY

1. Move only with a tractor. Never move by hand.
2. Stay away from overhead power lines when moving Auger. Electrocutation can occur without direct contact.

3. Keep Auger as low as possible.
4. Chock Auger and tractor wheels front and rear before operating.
5. Locate Auger to provide ample space for grain vehicles to unload.
6. Keep Auger as low as possible when moving. Raise only when it is next to storage facility.
7. Be familiar with the machine hazard area. If anyone enters hazard area, shut down machine immediately. Clear the area before restarting.
8. Operate the auger on level ground free of debris. If ground is uneven, anchor the auger to prevent tipping or upending.

### IMPORTANT

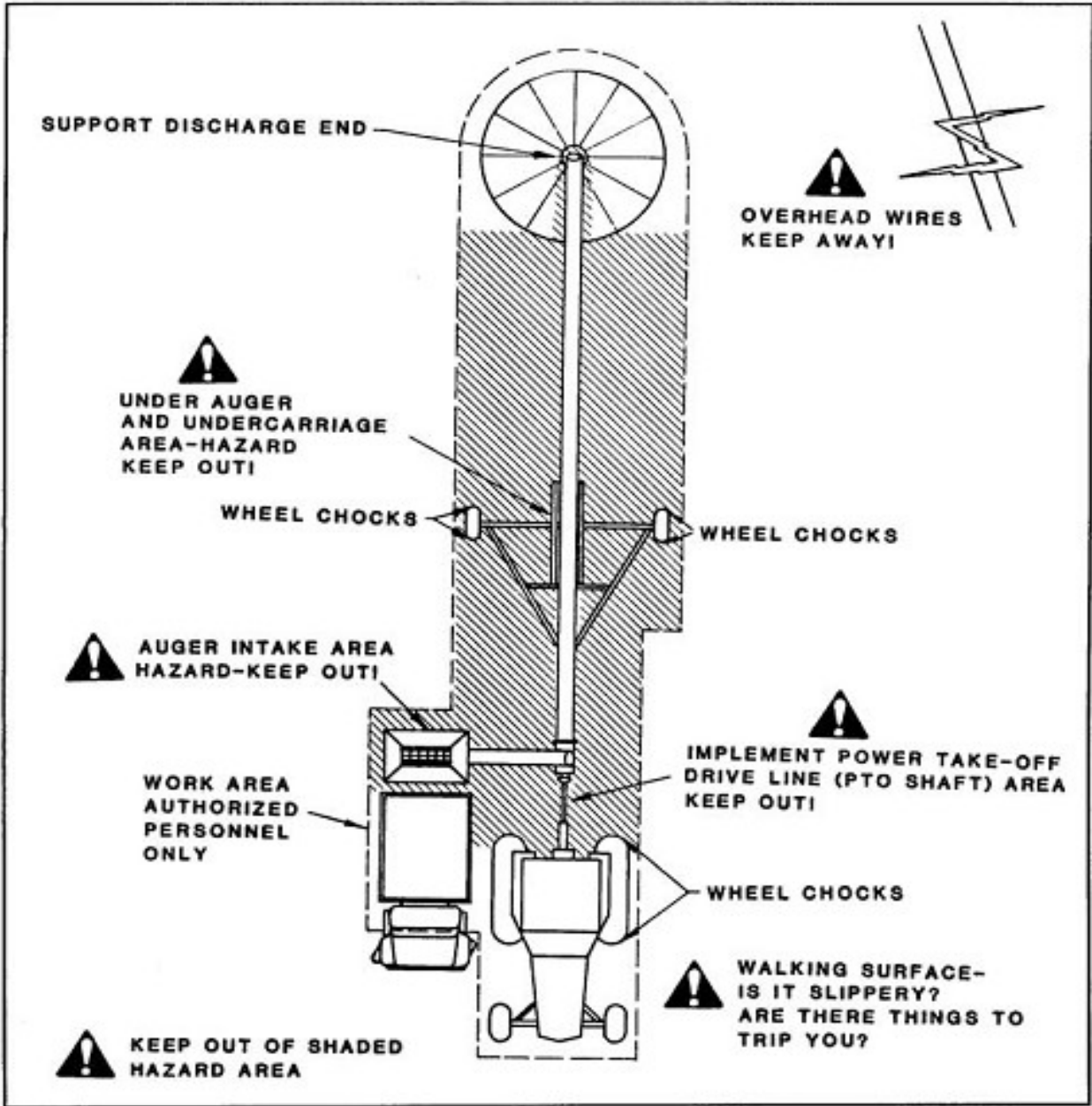
BEFORE RAISING OR PLACEMENT OF ENSURE THAT GROUND IS REASONABLY LEVEL. AUGER COULD TOPPLE IF GROUND IS TOO UNEVEN, DAMAGING EQUIPMENT AND/OR CAUSING PERSONAL INJURY.

**NOTE:** If auger wheels are partially or fully buried in snow or grain, do not attempt to move auger until snow or grain has been cleared away from auger wheels. Failure to heed may cause damage to auger and/or serious injury.

### IMPORTANT

WHEN RELEASING AUGER FROM THE TOWING VEHICLE, TEST THE INTAKE END FOR DOWNWARD WEIGHT. DO NOT RAISE THE INTAKE END ABOVE DRAW BAR HEIGHT. WHEN THE INTAKE END IS ELEVATED TOO HIGH WITH AUGER IN RAISED POSITION, THE BALANCE OF WEIGHT QUICKLY TRANSFERS TO THE DISCHARGE END, CAUSING THE AUGER TO UPEND.

**NOTE:** Winch must have clicking sound when raising auger. If clicking sound stops, retain grip on handle, lower the auger fully and repair ratchet.



**WORKPLACE HAZARD AREA**  
**TRACTOR PTO DRIVE**



## 2.4 MAINTENANCE SAFETY

1. Review the Operator's Manual and all safety items before working with, maintaining or operating the Auger.

2. Stop the engine, place all controls in neutral set park brake, remove ignition key and wait for all moving parts to stop before servicing, adjusting, repairing or unplugging.

3. Follow good shop practices:

-Keep service area clean and dry.

-Be sure electrical outlets and tools are properly grounded.

-Use adequate light for the job at hand.



4. Before applying pressure to a hydraulic system, make sure all components are tight and that hoses and couplings are in good condition.

5. Relieve pressure from hydraulic circuit before servicing or disconnecting from tractor.

6. Keep hands, feet, hair and clothing away from all moving and/or rotating parts.

7. Clear the area of bystanders, especially children, when carrying out any maintenance and repairs or making adjustments,

8. Place stands or blocks under the frame before working beneath the machine.

9. Before resuming work, install and secure all guards when maintenance work is completed.

10. Support auger tube before attempting maintenance on the under carriage assembly. Where possible auger should be in the full down position.

11. Keep decals clean. Replace any decal that is damaged or not clearly visible.

## 2.5 HYDRAULIC SAFETY

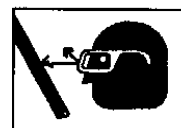
1. Always place all tractor hydraulic controls in neutral before disconnecting from tractor or working on hydraulic system.

2. Make sure that all components in the hydraulic system are kept in good condition and are clean.

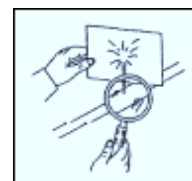
3. Replace any worn, cut, abraded, flattened or crimped hoses.

4. Do not attempt any makeshift repairs to the hydraulic fittings or hoses by using tape, clamps or cements. The hydraulic system operates under extremely high-pressure. Such repairs will fail suddenly and create a hazardous and unsafe condition.

5. Wear proper hand and eye protection when searching for high-pressure hydraulic leak.



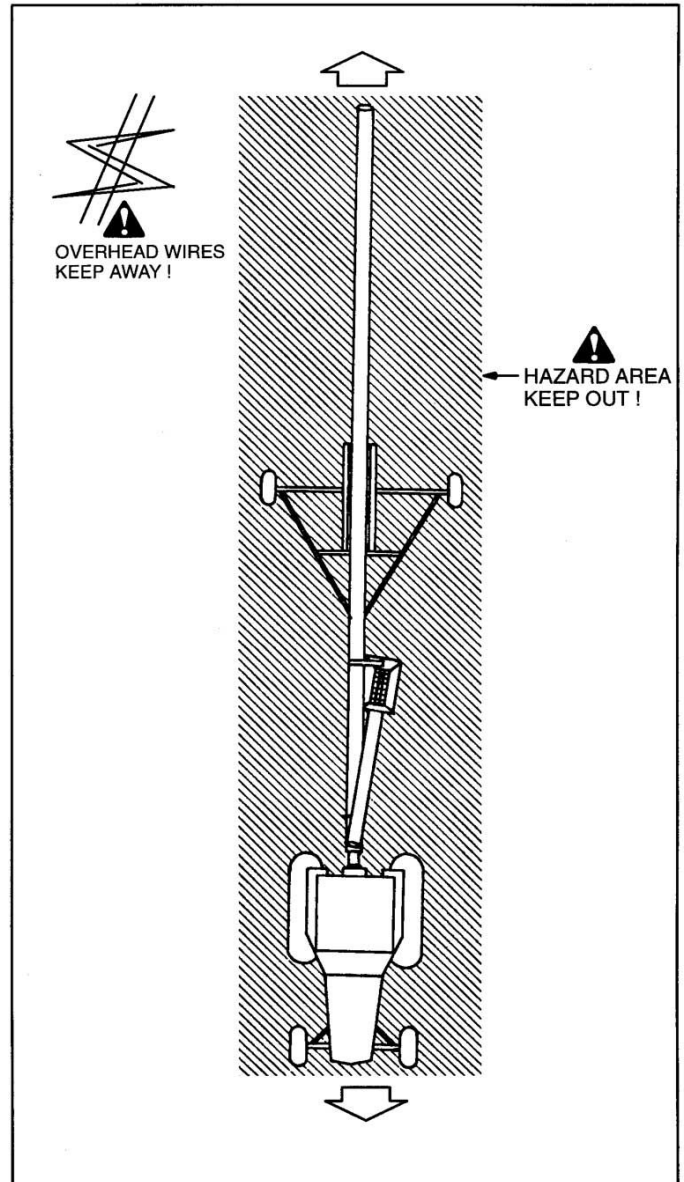
Use a piece of wood or cardboard as a backstop instead of hands to isolate and identify a leak.



6. If injured by a concentrated high-pressure stream of hydraulic oil, seek medical attention **immediately**. Serious infection or toxic reaction can develop from hydraulic fluid piercing the skin surface.

## 2.6 TRANSPORT SAFETY

1. Read and understand ALL the information in the Operator's Manual regarding procedures and SAFETY when moving or transporting the Auger.
2. Check with local authorities regarding Auger transport on public roads. Obey all applicable laws and regulations.
3. Always travel at a safe speed. Use caution when making corners or meeting traffic.
4. Make sure the SMV (Slow Moving Vehicle) emblem and all the lights and reflectors that are required by the local highway and transport authorities are in place, are clean and can be seen clearly by all overtaking and oncoming traffic.
5. Do not allow riders on the Auger or the tractor when transporting.
6. Attach Auger to towing vehicle with a bolt, washer and double nut. Always attach the safety chain.
7. Lower Auger to its lowest position for transporting.
8. Keep to the right and yield the right-of-way to allow faster traffic to pass. Drive on the road shoulder, if permitted by law.
9. Do not exceed 20 mph (32 km/h). Reduce speed on rough roads and surfaces.
10. Stay away from overhead obstructions and power lines when transporting. Electrocutation can occur without direct contact.
11. Always use hazard warning flashers on tractor when transporting unless prohibited by law.



### TRANSPORTING HAZARD AREA

**NOTE:** If auger wheels are partially or fully buried in snow or grain, **do not** attempt to move auger until snow or grain has been cleared away from the wheels. Failure to heed may cause damage to auger and/or serious injury.

## **2.7 STORAGE SAFETY**

1. Store the auger in an area away from human activity.
2. Do not permit children to play on or around the stored machine.
3. Lower the auger to its lowest position for storage unless placed in its operating position.

## **2.8 TIRE SAFETY**

1. Failure to follow proper procedures when mounting a tire on a wheel or rim can produce an explosion which may result in serious injury or death.
2. Do not attempt to mount a tire unless you have the proper equipment and experience to do the job.
3. Have a qualified tire dealer or repair service perform required tire maintenance.
4. When replacing worn tires, make sure they meet the original tire specifications. Never under-size.

## **2.9 SAFETY DECALS**

1. Keep safety decals and signs clean and legible at all times.
2. Replace safety decals that displayed a safety sign that are missing or have become illegible.
3. Replaced parts that displayed a safety sign should also display the current sign.
4. Safety decals or signs are available from your Dealers Parts Department or the factory.

### **How to Install Safety Decals:**

1. Be sure that the installation area is clean and dry.
2. Decide on the exact position before you remove the backing paper.
3. Remove the smallest portion of the split backing paper.
4. Align the decal over the specified area and carefully press the small portion with the exposed sticky backing in place.
5. Slowly peel back the remaining paper and carefully smooth the remaining portion of the decal in place.
6. Small air pockets can be pierced with a pin and smoothed out using the piece of decal backing paper.

**2.10 SIGN-OFF FORM**

Sheyenne/Westgo follows the General Safety Standards specified by the American Society of Agricultural Engineers (ASAE) and the Occupational Safety and Health Administration (OSHA). Anyone who will be operating and/ or maintaining the Portable Auger must read and clearly understand All Safety, operating and Maintenance information presented in this manual.

Do not operate or allow anyone else to operate this equipment until such information has been reviewed. Annually review this information before the season start-up.

Make these periodic reviews of SAFETY and OPERATION a standard for all of your equipment. We feel that an untrained operator is unqualified to operate this machine.

A sign off sheet is provided for your record keeping to show that all personnel who will be working with the equipment have read and understand the information in the Operator's Manual and have been instructed in the operation of the equipment.

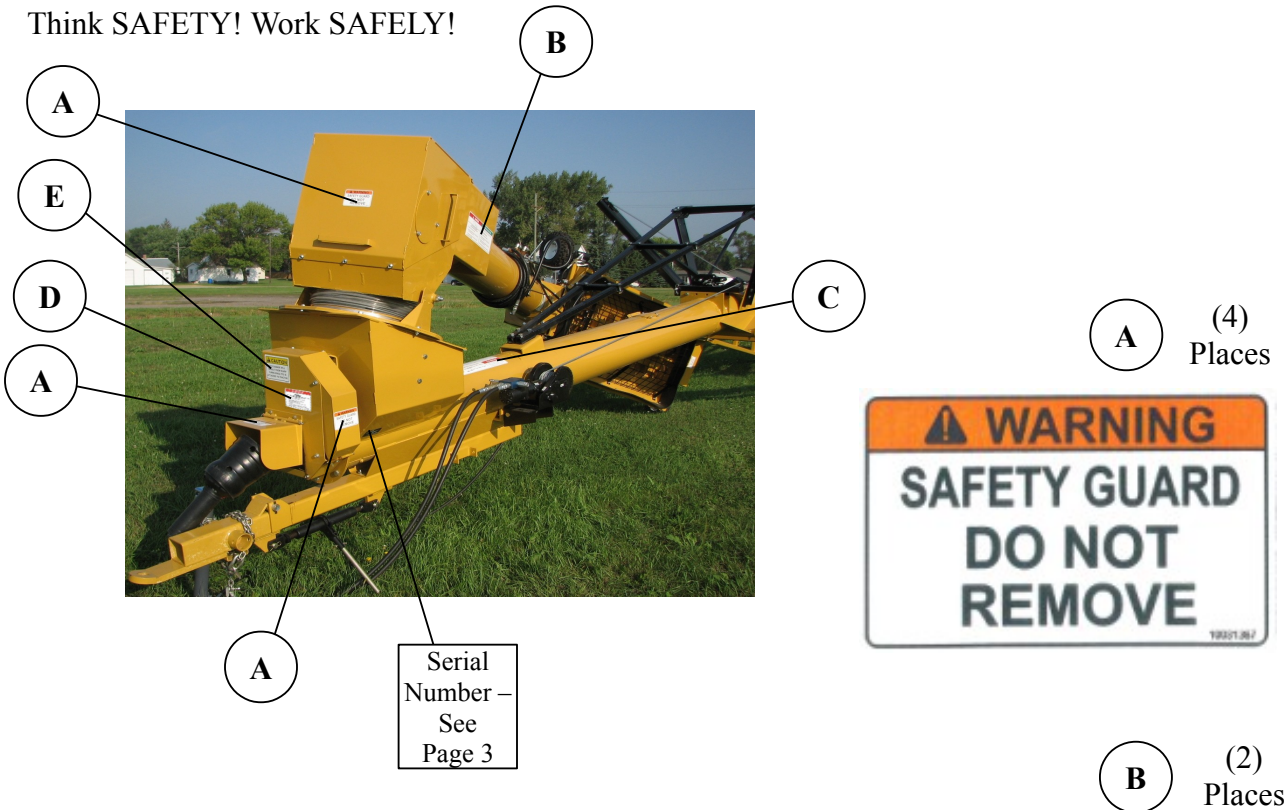
**SIGN-OFF FORM**

<b>DATE</b>	<b>EMPLOYEES SIGNATURE</b>	<b>EMPLOYERS SIGNATURE</b>

### 3. SAFETY DECAL LOCATIONS

The types of decals and locations on the equipment are shown in the illustration below. Good safety requires that you familiarize yourself with the various Safety Decals, the type of warning and the area, or particular function related to that area, that requires your SAFETY AWARENESS.

Think SAFETY! Work SAFELY!



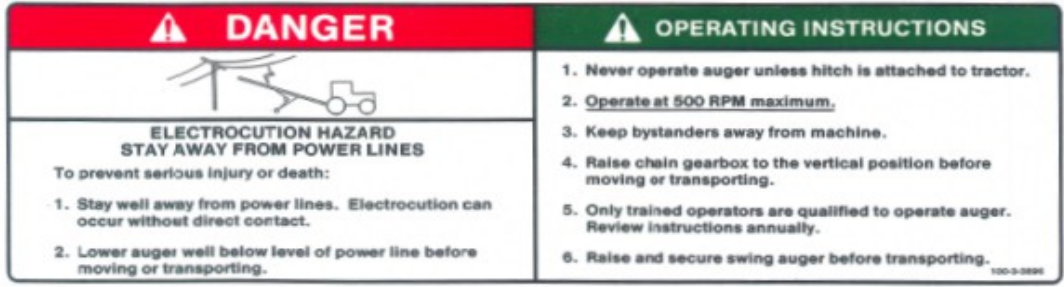
Serial Number – See Page 3

A

A (4) Places

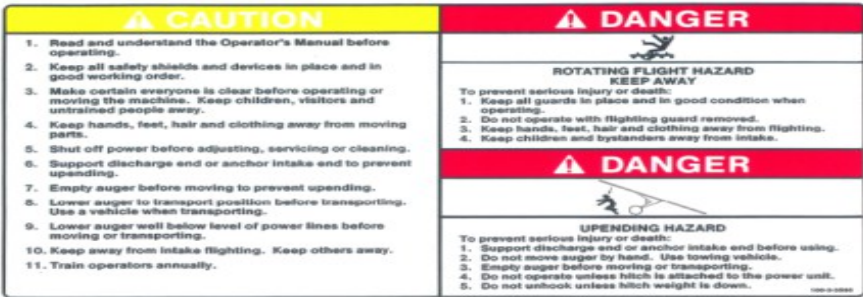


B (2) Places



C

D



If **Safety Decals** have been damaged, removed, become illegible or parts replaced without decals; new decals must be applied! New decals are available from your authorized dealer.

The types of decals and locations on the equipment are shown in the illustration below. Good safety requires that you familiarize yourself with the various Safety Decals, the type of warning and the area, or particular function related to that area, that requires your SAFETY AWARENESS.

Think SAFETY!

Work SAFETY!



E



F



F (2) Places



G



G

A

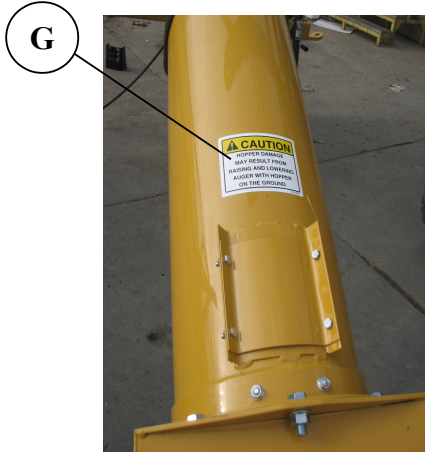


REMEMBER – If safety decals have been damaged, removed, become illegible or parts replaced without decals, new decals must be applied. New decals are available from your authorized dealer.

The types of decals and locations on the equipment are shown in the illustration below. Good safety requires that you familiarize yourself with the various Safety Decals, the type of warning and the area, or particular function related to that area, that requires your SAFETY AWARENESS.

Think SAFETY!

Work SAFETY!



H  
Vendor  
Decal



I Logo

J

K

L Individual  
Decals

REMEMBER – If safety decals have been damaged, removed, become illegible or parts replaced without decals, new decals must be applied. New decals are available from your authorized dealer.

## 4 OPERATION



### OPERATING SAFETY

1. Read and understand the Operator's Manual and all safety signs before using.
2. Stop the engine, place all controls in neutral, set park brake, remove ignition key and wait for all moving parts to stop before servicing, adjusting, repairing or unplugging.
3. Clear the area of all bystanders, especially children, before starting.
4. Be familiar with machine hazard area. If anyone enters hazard area, shut down (machine immediately. Clear the area before restarting.
5. Keep hands, feet, hair and clothing away from all moving and/or rotating parts.
6. Do not allow riders on the Auger or tractor when transporting.
7. Stay away from overhead obstructions and power lines during operation and transporting. Electrocutation can occur without direct contact.
8. Do not operate machine when any guards are removed.
9. Do not operate unless the flighting guard is installed and secure.
10. Set park brake on tractor before starting.
11. Attach Auger to tractor drawbar before operating.
12. Lower Auger to its lowest position when transporting or when not in use.

### 4.1 TO THE NEW OPERATOR OR OWNER

The Sheyenne/Westgo Portable auger is designed to efficiently move grain from a truck, trailer, or wagon into a storage facility. Power is provided by a tractor PTO. Be familiar with the tractor controls before starting.

**It is the responsibility of the owner or operator to read this manual and to train all other operators before they start working with the machine. Follow all safety instructions exactly. Safety is everyone's business. By following recommended procedures, a safe working environment is provided for the operator, bystanders and the area around the work site. Untrained operators are not qualified to operate this machine.**

Many features incorporated into this machine are the result of suggestions made by customers like you. Read this manual carefully to learn how to operate the machine safely and how to set it to provide maximum efficiency. By following the operating instructions in conjunction with a good maintenance program, your Auger will provide many years of trouble free service.

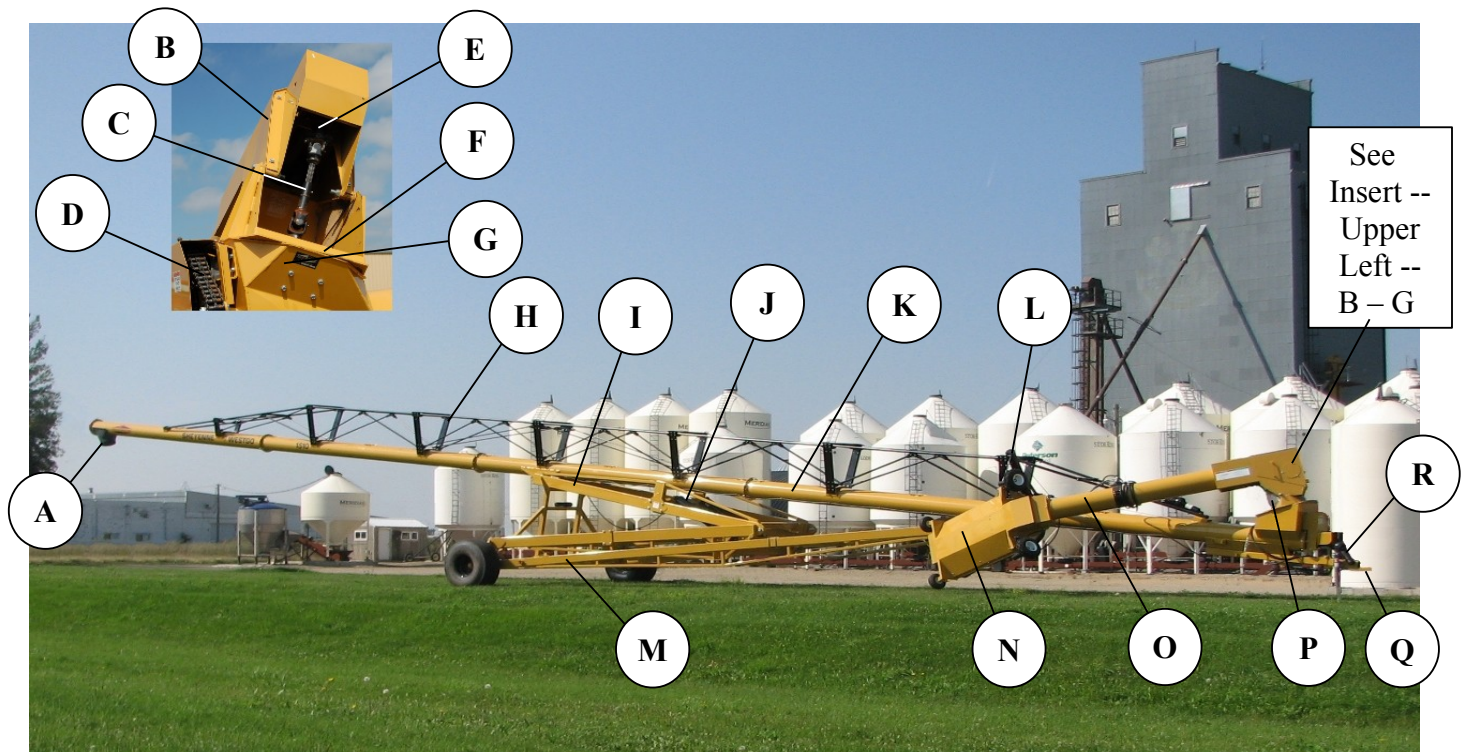


## 4.2 MACHINE COMPONENTS

The Portable Auger is a length of rotating flighting enclosed within a tube for moving grain. Grain enters the system through the swing away hopper. A winch lifts the swing away hopper for transport.

Power is provided from a tractor PTO that attaches to the lower end of the main auger. The swing hopper and inclined auger are driven by a chain drive and two gearboxes to an auxiliary driveline or an optional hydraulic motor. The movable drive system swings out to position for truck unloading.

The swing away hopper can be mounted on either the left or right hand sides. Two hydraulic cylinders in the frame raise and lower the machine. They use hydraulic power from the tractor.



**Fig. 1 MACHINE COMPONENTS**

**A** OUTLET – Main Auger Spout  
**B** INCLINED TUBE SPOUT  
**C** VERTICAL DRIVE LINE  
**D** CHAIN DRIVE  
**E** UPPER GEARBOX  
**F** LOWER PIVOT  
**G** LOWER GEARBOX  
**H** RIGID TRUSS  
**I** SISSOR LIFT

**J** LIFT CYLINDERS  
**K** MAIN TUBE  
**L** HOPPER TRANSPORT SUPPORT  
**M** AUGER TRANSPORT  
**N** SWING AWAY HOPPER - Intake  
**O** INCLINED TUBE  
**P** FLEX TUBE  
**Q** HITCH  
**R** PTO DRIVE LINE – From Tractor

### 4.3 MACHINE BREAK-IN

Although there are no operational restrictions on the Auger when used for the first time, it is recommended that the following mechanical items be checked:

A. After operating or transporting for 1/2 hour:

1. Re-torque all the wheel bolts.
2. Re-torque fasteners and hardware.
3. Check that all safety decals are installed and legible. Apply new decals if required.
4. Check that no hoses are pinched or being crimped. Re-align as required.
5. Check that all guards are installed and working as intended.
6. Check oil level in gearboxes. Add as required.
7. Check drive chain and tension and alignment. Adjust as required.
8. Lubricate all grease fittings.

B. After operating for 5 hours and 10 hours:

1. Re-torque all wheel bolts, fasteners and hardware.
2. Check hose routing.
3. Check that all guards are installed and working properly.
4. Check safety decals. Install new ones if required.
5. Check gearbox oil level. Add as required.
6. Check drive chain tension and alignment.
7. Then go to the normal servicing and maintenance schedule as defined in the Maintenance Section.

### 4.4 PRE-OPERATION CHECKLIST

Efficient and safe operation of the Sheyenne/Westgo Portable Auger requires that each operator reads and understands the operating procedures and all related safety precautions outlined in this section. A pre-operation checklist is provided for the operator. It is important for both the personal safety and maintaining the good mechanical condition of the Auger that this checklist is followed.

Before operating the Auger and each time thereafter, the following area should be checked off:

1. Lubricate the machine per the schedule outlined in Section 5 Service and Maintenance.
2. Use only a tractor of adequate power to operate the Auger.
3. Ensure that the machine is properly attached to the tractor drawbar. Use a 5/8 inch bolt, washers and double nut.
4. Check that all guards are installed, secured and functioning as intended. Do not operate with missing or damaged shields.
5. Check work-site. Clean up working area to prevent slipping or tripping.

## 4.5 ATTACHING / UNHOOKING

It is recommended that the Auger be attached to a tractor whenever it is operated or moved. Follow this procedure when attaching to or unhooking from tractor:

1. Make sure that bystanders, especially small children are clear of the working area.
2. Be sure that there is sufficient room and clearance to back up to the machine.

### IMPORTANT !

*Do not use a tractor that is equipped with a Quick Hitch! Remove the Quick Hitch before attaching. A Quick Hitch will hit the auger when making turns or it can contact the PTO drive-line if lowered during operation.*

3. When moving auger on rough or uneven terrain adjust axle to widest position. **See Fig 2.**



**Fig. 2 AXLE ADJUSTMENT**

4. Align the draw-bar of the tractor with the hitch of the auger while backing up.
5. Set the park brake before dismounting.
6. Check the auger to tractor mounting dimensions per the drawing prior to attaching. **See Fig. 3.** The auger is designed to be attached to a tractor during any operation including transporting, moving, raising, lowering or working. Because the unit must operate throughout a wide range of geometry, each dimension must be within a specified range. Verify that these dimensions fall within the recommended ranges before attaching.

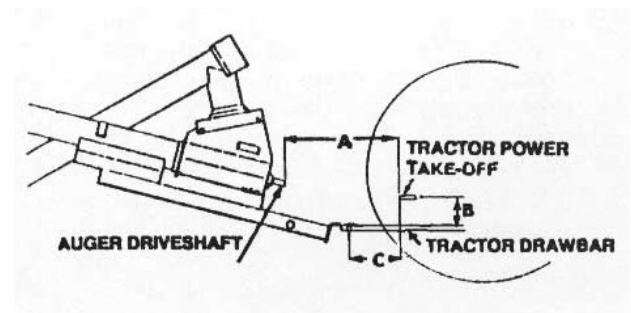
a. Dimension A: Must be within 34 and 36 inches. This works with the length of the PTO shaft supplied with the auger to allow telescoping and prevent bottoming out.

b. Dimension B: Must be within 6 to 10 inches. This will keep the angle of the universal joints equal and as small as possible. It also prevents bottoming out when the auger is raised.

c. Dimension C: Must be between 14 to 16 inches. This will prevent the PTO shaft from bottoming out when the auger is raised and prevent separation when the auger is lowered.

These dimensions are specified by Standards and most tractors comply. If your tractor does not comply, refer to your tractor manual and adjust to comply with these requirements.

7. Use the jack on the hitch to raise or lower the auger as required to match the draw-bar.



**Fig. 3 ATTACHING DIMENSIONS**

8. Use a 5/8 inch bolt as a hitch pin. Use large flat washers above and below the hitch and a nut and jam nut on the bolt. Do not tighten to draw-bar but jam the nuts together to hold. A bolt will allow free hitch movement whether the Auger is raised or lowered. **See Fig. 4a & 4b**

9. Attach the safety chain(s) to the draw-bar or draw-bar cage.



**Fig. 4a USE BOLT AS HITCH PIN**

10. Attach the PTO shaft:

- a. Clean the splines on the shaft and in the yoke if required.
- b. Check that the guard rotates freely and the drive-line telescopes easily. If not clean, lubricate or repair as required before installing.
- c. Retract collar on yoke and slide the yoke over the tractor shaft. Stop when the lock pin clicks into position in the groove.
- d. Pull on the yoke to make sure it is locked to the shaft.

### **IMPORTANT !**

*Never attach to tractor that is equipped with a PTO shaft adapter. It will change the required machine attaching dimensions and can lead to over speeding. Use only a tractor equipped with a 6 spline 540 RPM PTO shaft.*

11. Attach the hydraulic lines:

- a. Use a clean rag or paper towel to clean dirt from around the couplers on the hose ends and on the tractor.
- b. Connect the hoses to the tractor couplers. Be sure the couplers are securely seated.
- c. Route the hoses to prevent pinching rubbing or binding and allow enough slack for raising and lowering. Keep the hoses away from moving parts.

12. Open the valve in the hydraulic circuit to allow oil to flow to the cylinder for lowering or raising if required.



### **DANGER**

**Stay away from overhead power-lines. Electrocution can occur without direct contact.**

13. Raise and pin swing auger if moving.

14. Unpin and lower swing auger if preparing to work.

15. Lower hitch and stow the jack into its horizontal position.

16. Reverse the above procedure when unhooking.



**Fig. 4b ATTACHED**

## 4.6 MACHINE PLACEMENT

Follow this procedure when placing the auger into its working position:

1. Clear the area of bystanders, especially small children, before starting.
2. Be sure there is enough clearance from overhead obstructions and power lines or other equipment before moving the Auger into its working position.
3. Check the ground that the raised Auger will travel over. It **must** be level and free of holes, bumps or obstacles! Any of these present a very real threat of tipping.
4. Attach the Auger to the tractor (See Section 4.5).
5. Open the valve in the hydraulic circuit.
6. Back the Auger up to the storage facility while it is in its lowered configuration. See Fig. 5.



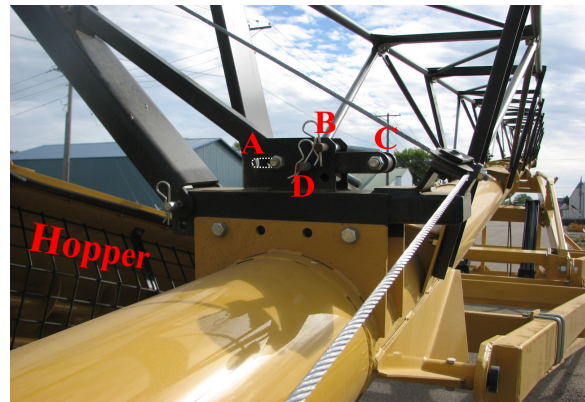
**Fig. 5 ALIGN AUGER WHILE IN LOWERED POSTION**

7. While the Auger is in this lowered position, four things need to be done; **1)** unhook the safety chain, see the **green** arrow in Fig. 6,



**Fig. 6 SAFETY CHAIN and HOOK - LIFT CABLE and HOOK**

- 2) put tension on the cable, see the **yellow** arrow in Fig. 6, taking pressure off of the pins marked “B” and “D” in Fig. 7, **3)** remove lock pin “B”



**Fig. 7 LIFT ARM OPERATION - HOPPER RAISED – ARM LOCKED**

- and pin “D” temporarily, **4)** lower the hopper. The notched linkage “C” will slide outward and tip up at end “C”, the bolt in slot “A” will move out to the outer end of the slot and the hopper will swing out and down. Return pin “D” to its original hole and key it. Put pin “B” in the lower unlock or “float” hole and key it. These pins are in position for the next time the hopper will be raised and locked for transport, see Fig 8.



**Fig. 8 LIFT ARM OPERATION - HOPPER LOWERED – ARM UNLOCKED**



### DANGER

Stay away from overhead power-lines. Electrocutation can occur without direct contact.

8. You are now ready to raise the Auger. From Fig. 5 to Fig. 9 there is a very large **angle** change. Three things need to be mentioned here. **1)** The lay of the land. Reminder of step 3



**Fig. 9 FULLY RAISED**

regarding tipping hazard. 2) Position of the hopper. Pages 16 and 17, item “G” show a decal that relates to the hopper during raising, lowering, backing or driving forward. Keep the hopper **near** to the ground, but not **on** the ground. The **red** arrows in **Fig. 9** illustrate these movements. Note how high the lift arm is in **Fig. 9**. The hopper should never be up to that height. 3) The cable winch. Two options are available; hydraulic or manual. The hydraulic option is easy to operate. For those with manual cable winch, the winch and crank will move up as the auger is raised. It should still be within reach (compare the **blue** arrows in **Figures 5 and 9**).

9. Use the tractor hydraulics to slowly raise the outlet end into position. **Stay away** from power lines. See **Fig. 9**.

10. Slowly back the auger until the outlet is over the opening in the storage facility.

11. Slowly lower the outlet end until it is resting on the storage facility. Leave the hitch attached to the tractor.

12. Place chocks in the front and rear of each auger wheel and some tractor wheels.

13. Lower the hopper to ground and **unhook** the cable (see the **orange** arrow in **Fig. 6** on page 23).

14. The hopper can now be positioned for end dump trucks. Hopper bottom semi-trailers need to be driven into position first and the hopper brought in under the grain door(s). The power wheel option is an important labor saving tool in this application, see **Fig. 10**.

15. Check that all access covers and the clean out door are securely in place.

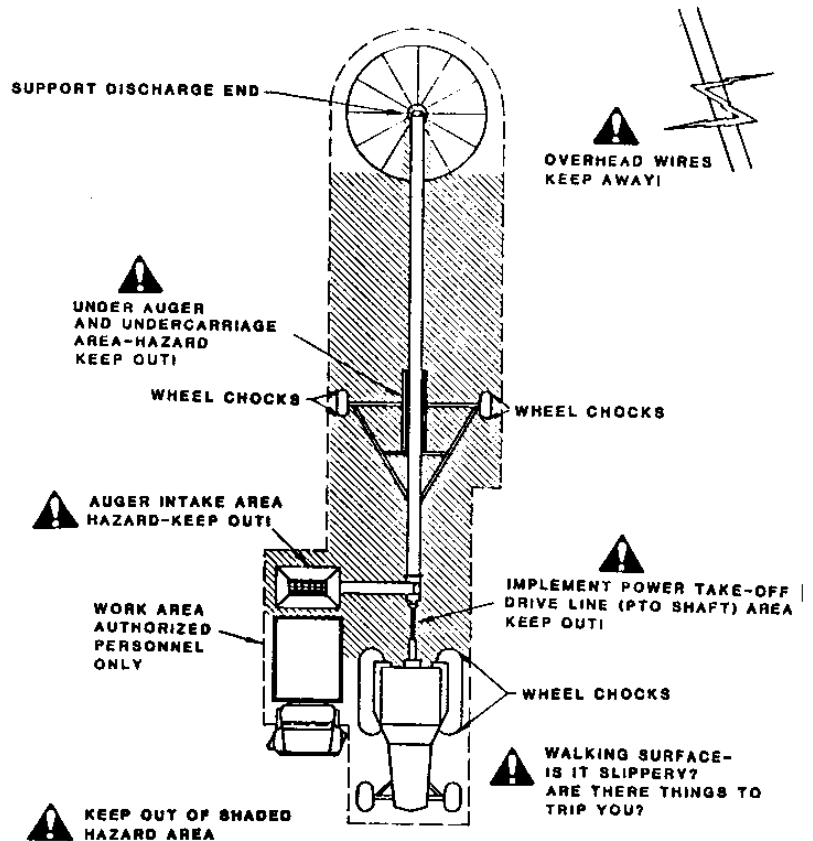


**Fig. 10 TRANSFERRING GRAIN FROM TRUCK TO BIN**

## 4.7 OPERATING

When using the Auger, follow this procedure:

1. Clear the area of bystanders especially small children, before starting.
2. Review the Pre-Operation Checklist (Section 4.4) before starting.
3. Review the Workplace Hazard Area drawing and use extra care when inside the hazard area. See Fig. 11. Keep all spectators and bystanders out of this area. Should anyone enter this area, stop the machine immediately.
4. Check that the machine is placed per Section 4.6.
5. Back a tractor up to the inlet end and attach with a bolt, washers and double nuts. Attach the PTO driveline. Align the tractor axis with the Auger so the universal joints are equal and as small as possible. Place chocks next to tractor tires and set the park brake.
6. Check that the driveline out of the gearbox is secured to the output shaft.
7. Check that all guards are in place and working as intended.

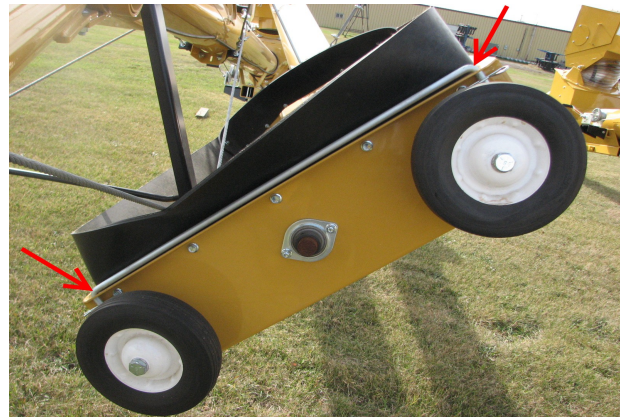


**Fig. 11** WORKPLACE HAZARD AREA

8. Move the swing hopper out of the way. Normally this will be up against the frame.
9. Drive or back the truck into position for unloading.
10. Use the handle on the hopper to move the swing auger into position under the truck. See **Fig. 12a**.



**Fig. 12a** Swinging Out, Manually moved



**Fig. 12b** Store Handle  
**SWING AWAY HOPPER**

11. Starting:
  - a. Start the tractor engine and run at low idle.
  - b. Engage the PTO clutch.
  - c. Activate the circuit to the motor if equipped with the hydraulic drive option.
  - d. Increase engine speed to 500 RPM PTO speed.

12. Start the flow or grain and unload.
13. When the truck is unloaded and PTO is shut off, move the swing hopper out of the way and store the handle. See **Fig. 12b**.
14. **Optional Power Wheel** drive system. Either double wheel or single wheel drive. See **Fig. 12c** and **12e** thru **12i**.



**Fig. 12c** Power Wheel Option, Hydraulic Double or Single



**Fig. 12d** Double Power Wheel, Prior to June 2011

The above power wheel design was built between Mar 2002 and Jun 2011.

Earlier models had hydraulic motors with o-ring ports. Upper level part no. 100-1-0782.

Later models had motors with pipe thread ports. Upper level part no. 100-2-2878.



New design Power Wheel – lighter and more compact. June 2011 and forward.  
Top level assembly part number is 100-1-0881.



**Fig. 12e Double Power Wheel**



**Fig. 12h Right Hand, Close-up**



**Fig. 12f Outer End of Hopper**



**Fig. 12i Unloading Grain**



**Fig. 12g Left Hand, Close-up**



## 14. Stopping:

- a. Run the auger until the swing hopper is empty.
- b. Slow the engine speed to low idle.
- c. Disengage PTO clutch.
- d. Shut off hydraulic motor if so equipped.
- e. Stop engine and remove ignition

## 15. Operating Hints:

- a. Run the unit at approximately 500 RPM to obtain the most consistent results.
- b. Always listen for any unusual sounds or noises. If any are heard, stop the machine and determine the source. Correct the problem before resuming work.
- c. Never allow anyone into the workplace hazard area. If anyone enters, stop immediately. Make them go before resuming work.
- d. Do not run the machine for long periods of time with no grain in the tube. It is noisy and increases the wear. Try to run only when moving grain.
- e. Do not move the machine by hand, Always use a tractor.
- f. Always locate the swing hopper within 20 degrees of a right angle to the main tube for optimum performance. **See Fig. 13.**
- g. When the auger is used to put grain in a pile, the grain can build up and cover the wheels. It is recommended that the operator attach a log chain to each axle when the auger is positioned. Before pulling the auger out of the pile, pull the chains tight and attach to the drawbar. This will prevent axle or frame bending.

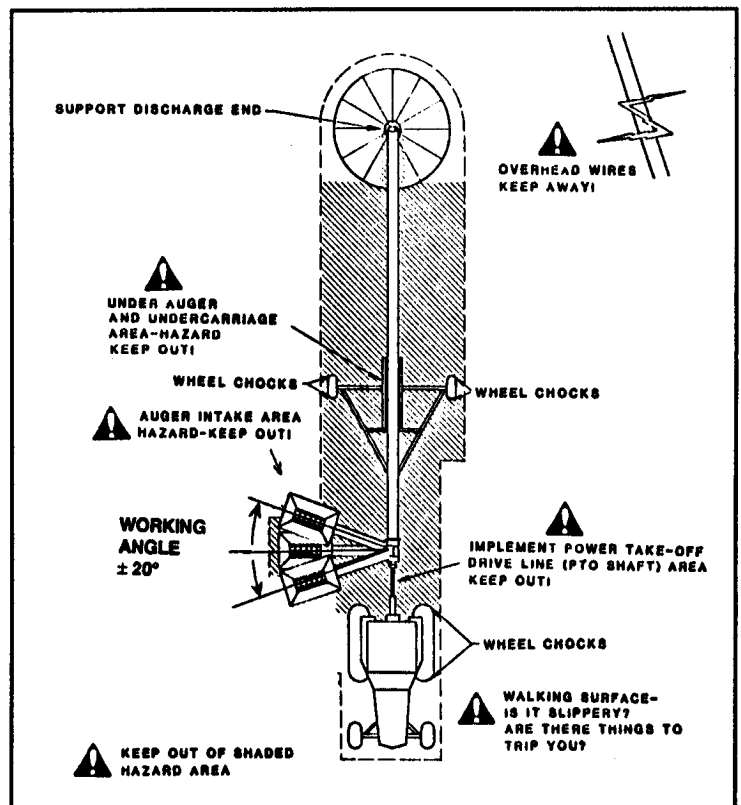


Fig. 13 SWING AWAY HOPPER POSITION

## 4.8 TRANSPORTING SAFETY



Sheyenne/Westgo Portable Augers are designed to be easily and conveniently moved from place to place. When transporting, follow this procedure:

1. Read and understand ALL the information in the Operator's Manual regarding procedures and SAFETY when moving or transporting the Auger.
2. Check with local authorities regarding Auger transport on public roads. Obey all applicable laws and regulations.
3. Always travel at a safe speed. Use extra caution when making corners or meeting traffic.
4. Cornering requires addition care for two reasons. These long machines cut across corners and the inside wheel may drop into a ditch. Secondly the top or back end makes a wide outward “swing” when cornering. Be watching surrounding objects.
5. Make sure the SMV (Slow Moving Vehicle) emblem and all the lights and reflectors that are required by the local highway and transport authorities are in place, are clean and can be seen clearly by all overtaking and oncoming traffic.
6. Do not allow riders on the Auger or the Tractor when transporting. Clear the area of any bystanders.
7. Attach the Auger to the tractor with a bolt, washer and **double nut**. Note that the length of the bolt provides **ample space** for the auger tongue to **change angle** as the auger is raised later. Always attach the safety chain. See **Fig. 14a**.



**Figure 14a. HITCH**

8. Lower Auger to its lowest position for transporting.
9. Keep to the right and yield the right-of-way to allow faster traffic to pass. Drive on the road shoulder, if permitted by law.
10. Do not exceed 20 mph (32 km/h). Reduce speed on rough roads and surfaces.
11. Stay away from overhead obstructions and power lines when transporting. Electrocution can occur without direct contact.
12. Always use hazard warning flashers on tractor when transporting unless prohibited by state law.
13. **Fig. 14b** shows the PTO shaft supported by a bracket. That is OK when unhooking the tractor; however for road transport the outer half of the PTO should be **removed** and carried in a safe manor. Do **not** allow it to slide out and fall on the ground or road or be damaged when turning!



**Figure 14b. DISCONNECT PTO**

5. Use the winch to raise the swing auger or hopper off the ground. Attach the hook so the wire mesh and rubber belt are against the main tube.

6. Raise until the cable clamp contacts the support arm. See fig. 15.



**Fig. 15 CABLE CLAMP (ARROW), CURRENT LIFT ARM MECHANISM**

7. Raise the swing auger further until the support is against its stop and the hopper is against the main tube. See fig. 16.

8. Install the swing hopper transport rod and its retainers.

9. Place the hitch jack into its transport position.

10. Attach the hydraulic line, open the valve and lower the machine if required. Transport only when auger is in its lowest position.

11. Stay away from overhead power lines.

**DANGER**



**Stay away from overhead power-lines. Electrocutation can occur without direct contact.**

12. Never go across slopes of more than 20 degrees. It is better to go straight up or straight down.

13. Keep to the right and yield the right-of-way to allow faster traffic to pass. Drive on the road shoulder, if permitted by law.

14. Make sure the SMV (Slow Moving Vehicle) emblem and all the lights and reflectors that area required by the local highway and transport authorities are in place, are clean and can be seen clearly by all overtaking and oncoming traffic,

15. It is not recommended that the machine be transported faster than 20 mph (30 km/h). Table 1 gives the acceptable transport speed as the ratio of tractor weight to Auger weight.

16. Do not allow riders on the machine or tractor.

17. During periods of limited visibility, use pilot vehicles or add extra lights to the machine.

18. Always use hazard flashers on the tractor when transporting unless prohibited by law.




**Fig. 16 FULLY RAISED HOPPER**

**Table 1 Speed vs Weight Ratio**

<u>Road Speed</u>	<u>Weight of fully equipped or loaded implement(s) relative to weight of towing machine</u>
Up to 32 km/h (20 mph)	1 to 1, or less
Up to 16 km/h (10 mph)	2 to 1, or less
Do not tow	More than 2 to 1

## 4.9 STORAGE

 <b>STORAGE SAFETY</b>
1. Store the unit in an area away from human activity.
2. Do not permit children to play on or around the stored machine.
3. Lower Auger to its lowest position for storage unless placed in its operating position.

After the season's use, the machine should be thoroughly inspected and prepared for storage. Repair or replace any worn or damaged components to prevent any unnecessary down time at the start of the next season. To insure a long, trouble free life, this procedure should be followed when preparing the unit for storage:

1. Wash the entire machine thoroughly using a water hose or pressure washer to remove all dirt, mud, debris or residue.
2. Inspect all moving or rotating parts to see if anything has become entangled in them. Remove the entangled material.
3. Lubricate all grease fittings to remove any moisture in the bearings.
4. Run the machine slowly for 1 minute to distribute lubricant to all surfaces.
5. Apply a light coat of oil to the roller chain while the unit is running to prevent rusting.
6. Inspect all hydraulic hoses, fittings, lines, couplers and valves. Tighten any loose fittings. Replace any hose that is badly cut, nicked or abraded or is separating from the crimped end of the fitting.
7. Touch up all paint nicks and scratches to prevent rusting.

8. Select an area that is dry, level and free of debris. For those in northern climates, storage areas where deep snow drifts occur should be avoided.

9. If the auger is not being left in a storage facility, it should be placed in its lowest position.

10. Have the hitch jack stand on the same side as the hopper. This provides better support.

10. It is recommended that the swing auger hopper be lowered to rest on the ground for long term storage. Wooden blocks would keep the hopper out of the dirt. Removing weight from the hopper lift arm will release the twisting load on the frame.

11. Follow the procedure given in Section 4.6 when unhooking.



**Fig. 17 STORAGE**

## 5 MAINTENANCE AND SERVICE



### MAINTENANCE SAFETY

1. Review the Operator's Manual and all safety items before working with, maintaining or operating the Auger.
2. Stop the engine, place all controls in neutral set park brake, remove ignition key and wait for all moving parts to stop before servicing, adjusting, repairing or unplugging.
3. Wear appropriate protective gear. This list includes but is not limited to:
  - A hard hat
  - Protective shoes with slip resistant soles
  - Protective goggles
  - Heavy gloves
  - Hearing protection
  - Respirator or filter mask
4. Before applying pressure to a hydraulic system, make sure all components are tight and that hoses and couplings are in good condition.
5. Relieve pressure from hydraulic circuit before servicing or disconnecting from tractor.
6. Keep hands, feet, hair and clothing away from all moving and/or rotating parts.
7. Clear the area of bystanders, especially children, when carrying out any maintenance and repairs or making adjustments.
8. Place stands or blocks under the frame before working beneath the machine.
9. Before resuming work, install and secure all guards when maintenance work is completed.

## 5.1 SERVICE

### 5.1.1 FLUIDS AND LUBRICANTS

#### 1. Grease

Use an SAE multi-purpose high temperature grease with extreme pressure (EP) performance. Also acceptable is an SAE multi-purpose lithium based grease.

#### 2. Lubricating oil

Use a standard automotive oil for all requirements.

#### 3. Gearbox oil

Use an SAE 85W90 gear oil for all operating conditions.

Gearbox Capacity: 1 U.S. quart (0.85 liter)

#### 4. Storing Lubricants

Your machine can operate at top efficiency only if clean lubricants are used. Use clean container to handle all lubricants. Store them in an area protected from dust, moisture and other contaminants.

### 5.1.2 GREASING

Use the Maintenance Checklist provided to keep a record of all scheduled maintenance.

1. Use a hand-held grease gun for all greasing.

2. Wipe grease fitting with a clean cloth before greasing, to avoid injecting dirt and grit.

3. Replace and repair broken fittings immediately.

4. If fittings will not take grease, remove and clean thoroughly. Also clean lubricant passageway. Replace fitting if necessary.

5.1.3 SERVICING INTERVALS

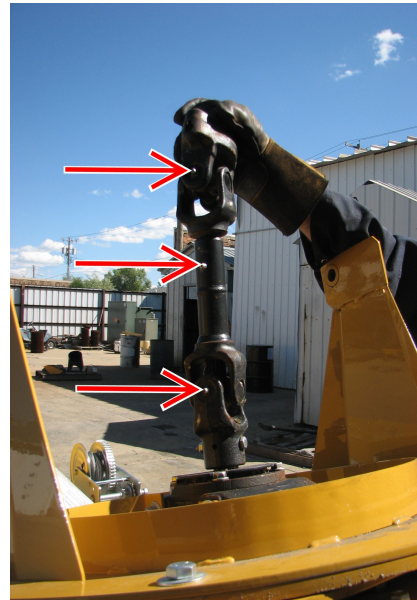
**10 HOURS OR DAILY**

1. Grease PTO shaft (5 locations).



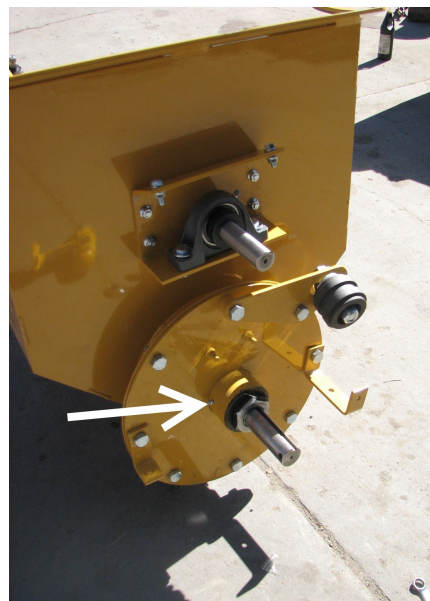
**Fig. 18 PTO SHAFT (HORIZONTAL), FIVE**

2. Grease vertical PTO shaft (3 locations).



**GREASE ZERK ACCESS HOLES  
Fig. 19 DRIVE SHAFT (VERTICAL)**

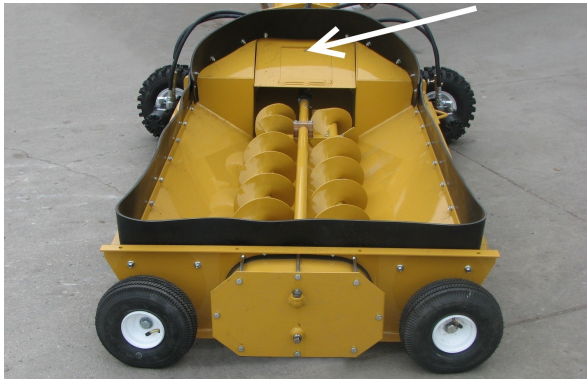
3. Grease chain drive sprocket bearing (1 Location)



**Fig. 20**



4. Grease all three grease fittings at the upper end of the grain hopper. Remove the small access cover shown by the arrow in **Fig. 21**. The double constant velocity joint has two zerks and the slide above them has one. Avoid over greasing.



**Fig. 21 Grease double CV joint & slide**

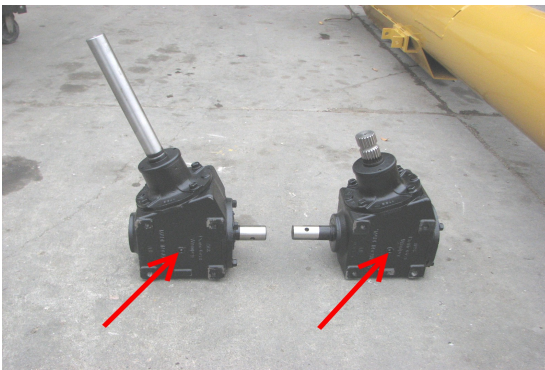
#### **40 HOURS OR WEEKLY**

1. Oil the roller chain with a light coat of oil.



**Fig. 23 Oil roller chain**

5. Check gear box oil levels. There are two gear boxes, one at each end of the vertical PTO shaft. Add as required. Fill to check plug level, see **Fig 22**.



**Fig. 22 Gearbox 'check oil level' plugs**

#### **200 Hours or Annually**

1. Repack wheel bearings



**Fig. 24 Repack Wheel Bearings**

#### **Note:**

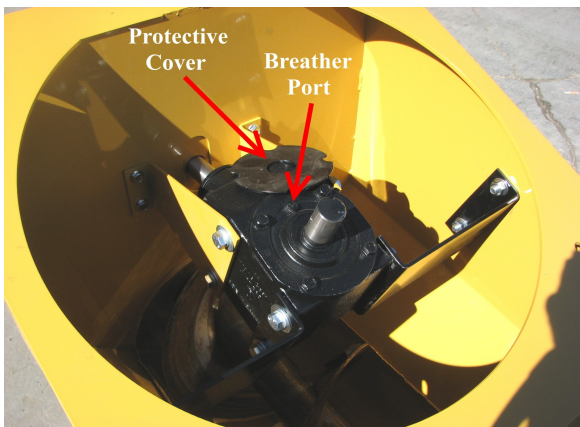
Check when the oil is cold and the auger is as near to level as possible.



## 200 Hours or Annually (cont.)

### Breather cleaning

Clean the gearbox breather ports. Lift the protective cover and inspect. Wipe the port clear of dirt.



**Fig. 25 LOWER GEARBOX BREATHER PORT**

## 5.2 MAINTENANCE

By following a careful service and maintenance program for your machine, you will enjoy many years of trouble free-service.

### 5.2.1 CHAIN TENSION

The roller chain on the input drive should always be adjusted so the chain is snug with only a slight amount of movement at the center of the span.

To adjust, follow this procedure:

1. Stop engine and remove ignition key.
2. Loosen the jam nuts on the adjusting bolts on both sides.
3. Turn the adjusting bolts to adjust the tension. Turn both the same amount to maintain sprocket alignment.
4. Check the tension by inserting a screw driver into the slot. The center of the span should be just snug.
5. Tighten the jam nuts.



**Fig. 26 Chain tensioner**

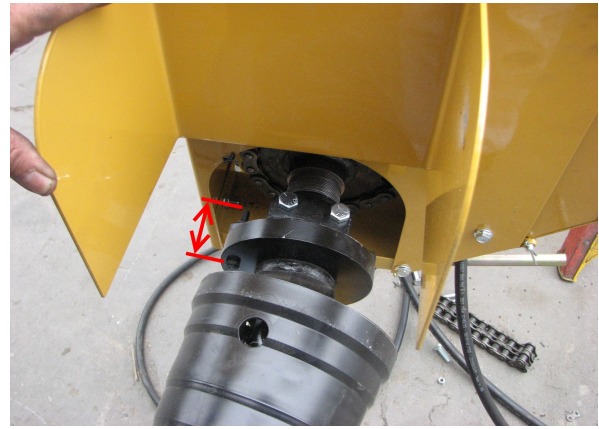
### 5.2.3 SHEAR BOLTS

The input PTO driveline (main driveline) is equipped with a shear bolt to protect against overloads for the whole auger (**Fig. 27a**).

The vertical driveline in the pivot drive is also shear bolt protected (**Fig. 27b**). Just the pivot drive, the inclined auger and the hopper are protected here. This driveline has **two** uneven length shear bolts. When assembled these bolts are at the upper end of the PTO as shown.

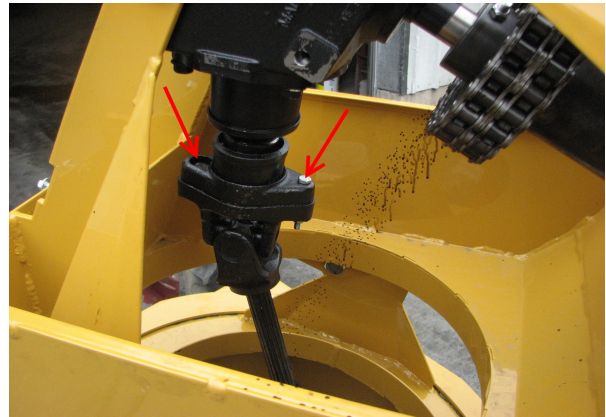
To replace bolts, follow this procedure:

1. Stop engine and remove ignition key.
2. Remove any bolt parts remaining in the mating parts.
3. Install a new bolt using genuine Sheyenne/Westgo parts and tighten.



**Fig 27a PTO DRIVELINE SHEAR BOLT**

- (1) 5/16UNC x 2-1/2 hex bolt, grade 5  
Part number 900-01071
- (1) 5/16UNC toplock nut  
Part number 900-06498

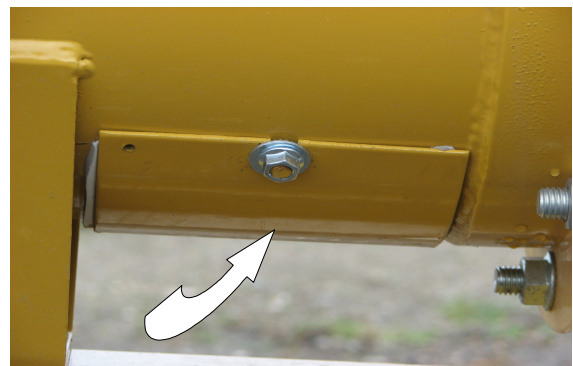


**Fig. 27b VERTICAL DRIVELINE**

- (1) 1/4UNC x 1" hex bolt, grade 5  
Part number 100-3-5361
- (1) 1/4UNC x 2-1/4 hex bolt, grade 5  
Part number 100-3-5362
- (2) 1/4UNC toplock nut  
Part number 900-06496

### 5.2.4 CLEAN OUT DOOR

A small clean out door is located on the bottom of the tube at the lower end (**Fig. 28**). Clean the tube by opening this door. Stop engine and remove ignition key or remove PTO driveline before opening door.



**Fig. 28 CLEAN OUT DOOR**

## Instructions for Replacing the Double Constant Velocity Joint

1. Check that the support cross rod is properly adjusted. The rod should be tightened so dimension "B" is equal to dimension "A". See figure 29.

2. Remove the safety mesh. Note: After installing the constant velocity (CV) joint, it is important that the safety mesh be reinstalled (only remove for installation). The mesh provides required structural support to the hopper. Remove the 5/16 bolts that hold the CV joint to the helicoids. (Models prior to 1997 may have a flex shaft. Flex shafts are no longer available.) Do not use a hammer to remove bolts; the helicoids will bend causing vibration.

3. Remove hopper from inclined tube assembly.

4. Grease the inside end of the hopper helicoid; insert the hex connector so the holes align. Guide a 5/16 x 2 bolt through the hole in the hopper helicoid and tighten with a locknut.

5. Bolt tube connector to CV joint using 5/16 x 2 1/2 bolt and lock nut.

6. Grease inside end of inclined tube helicoid; insert end of tube connector into the helicoid. Fasten with /16 x 2 bolt and locknut. Do not tighten until final adjustment (see step 8).

7. Guide the incline tube on to the hopper, the angle ring spacer (use only for augers sold prior to 1994) held in between them. At the same time, the CV joint must be guided onto the hex connector, only guide the CV joint on to the hex connector where the helicoids will not interfere with each other (rotate the hopper helicoid to the desire position).

Where the end of the hopper flighting ends, the inclined tube flighting should begin. Use 1/2 x 2 1/2 bolts for a 10" auger and 7/16 x 2 1/2 bolts for an 8" auger to assemble the hopper to the inclined tube.

8. Adjust CV joint so that it is approximately 1/4" from bottoming out on the hex connector. Tighten locknut at inclined tube connection.

9. Slowly rotate the hopper helicoid and visually check that the flighting ends are at least 1/4" away from the CV joint in all positions. Torch flighting to remove any interfering material. Be careful not to cut the CV joint or connectors.

10. REMEMBER TO RE-INSTALL THE SAFETY MESH. THIS IS VERY IMPORTANT.

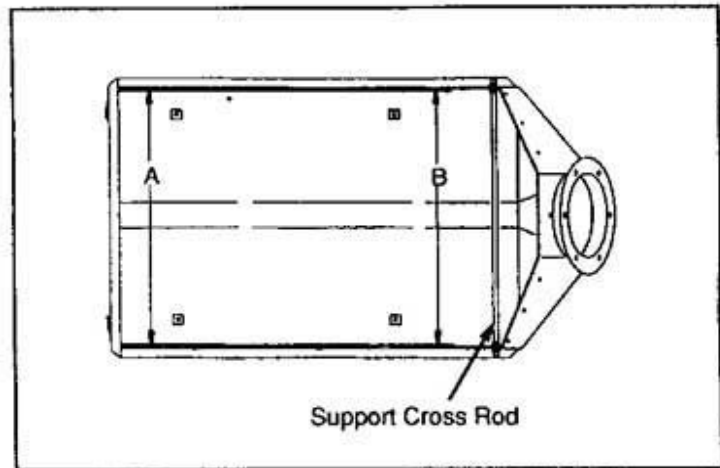


Fig. 29 HOPPER

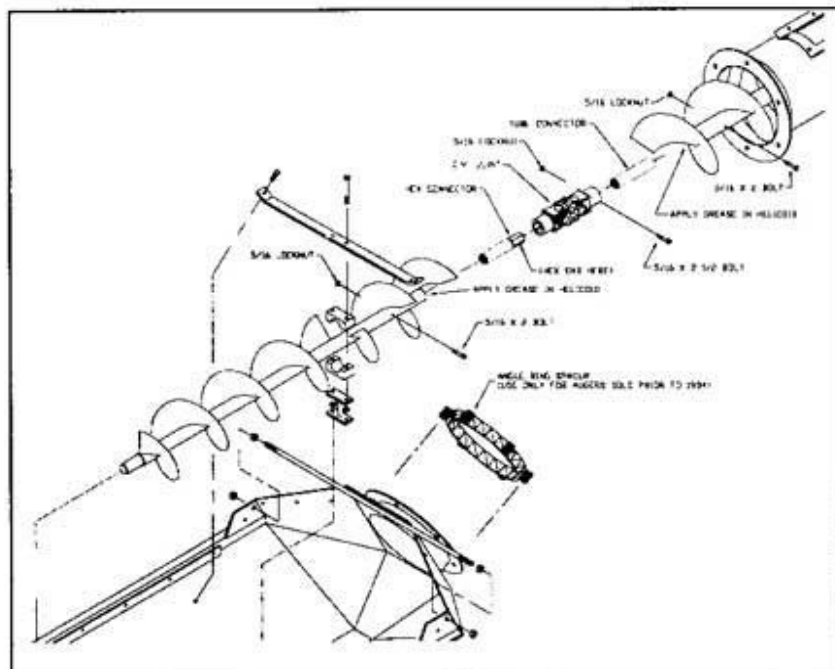
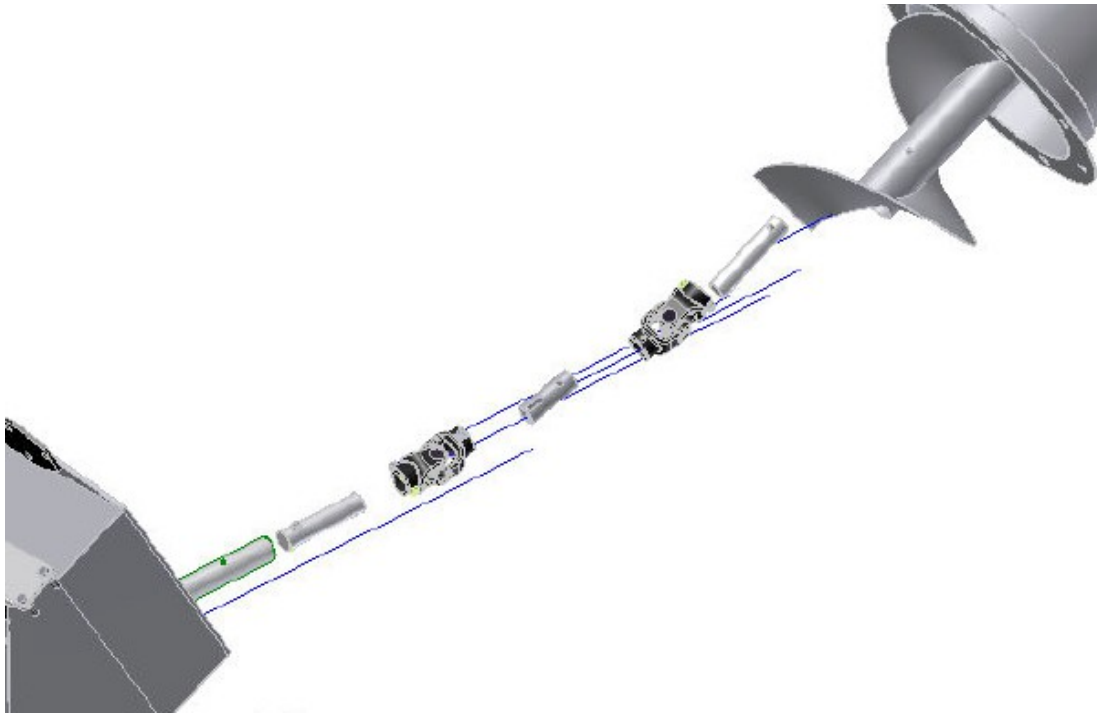


Fig. 30 DOUBLE CONSTANT VELOCITY JOINT

## CURRENT MODEL HOPPER U-JOINTS



**Fig. 31 Two U-Joint Hopper Drive**

Figure 31 above shows the proper assembly sequence and orientation of parts to connect the inclined auger helicoid to the drive shaft in the hopper.

To replace any of these parts you should follow the steps for the double CV joint on the previous page (38). The part descriptions and part numbers are different, but the steps are the same.

### **5.2.6 INCLINE AUGER HANGER BEARING BEARING**

An access door is located on the incline auger to allow hanger bearing replacement. Stop engine and remove ignition key or remove the PTO driveline before opening access door. Install and secure the door before resuming work.



**Fig. 32 INCLINE AUGER ACCESS DOOR**

### 5.2.7 INCLINE AUGER AND HOPPER MOUNTING OPTION

The winch and support frame for lifting and holding the swing auger can be mounted on either side of the machine.

Remove and mount to the opposite side if required. Remove the mounting pins for each component when moving. Install the retainers in the pins before raising the hopper and inclined auger.

Orientation of the auger, left, right, front and rear was covered on page 5. Note the descriptions under the photos on this page.

A simple way to think of the tractor and auger is to compare them to a semi tractor-trailer rig. The left side “runs up” the whole side of the rig even though the driver is seated quite far forward. Unhooking the trailer doesn't change the left and right of the trailer.

Don't reverse the *left* and *right* of the auger just because the tractor driver turns around or unhooks the auger from the tractor.

Grain goes in the hopper (the front) and exits the spout (the back).



**Hopper On The Left**



**Hopper On The Right**

**Fig. 33 ALTERNATE INCLINE AUGER AND HOPPER POSITIONS**



## 6 TIMING THE FLIGHTING

### 6.1 HANGER BEARINGS, 1510 AUGER

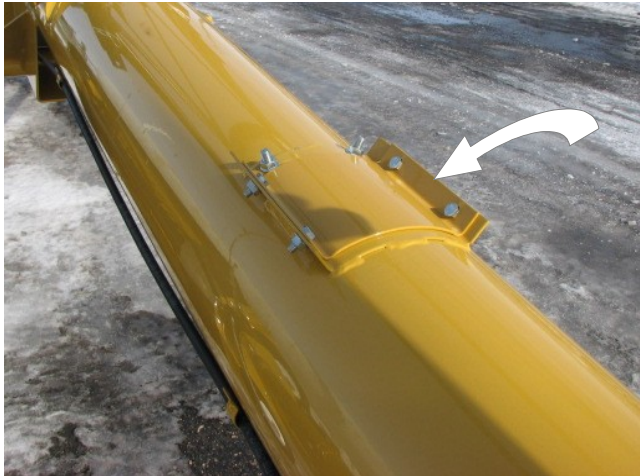
On the 1510 augers the flighting is supported by hanger bearings every 10 feet (3 m). Although they do not require lubrication, they can fail after extended periods of use. Normally failure will be accompanied by an increase in noise level. Access covers on the top of the tubing allow access for bearing replacement.

To replace bearing, follow this procedure:

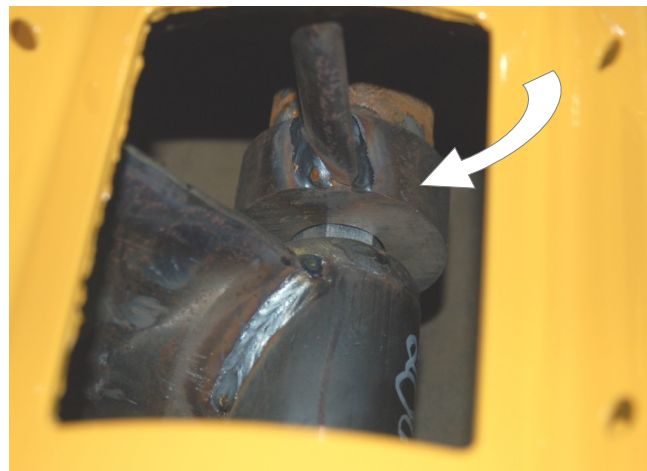
1. Clear the area of bystanders, especially small children.
2. Remove power as appropriate:
  - a. Disconnect PTO shaft from tractor.
  - b. Turn electric motor OFF and lock out power at master panel.
3. Remove access cover next to failed bearing and the access covers the rest of the way down the auger. See fig. 34.
4. Remove bolts from the hanger bearings next to the access cover holes.
5. Remove intake bearing assembly from the bottom of the auger.
6. Replace the hanger bearing that has failed. See fig. 35. **Use only genuine Sheyenne/Westgo replacement parts.**

#### **IMPORTANT TIMING INFORMATION!**

7. Slide flighting sections and bearing assemblies back into tube. The hex shafts and the flighting sockets to which they mate **“time”** the flighting. To do justice to this very important topic we direct you to page 43.

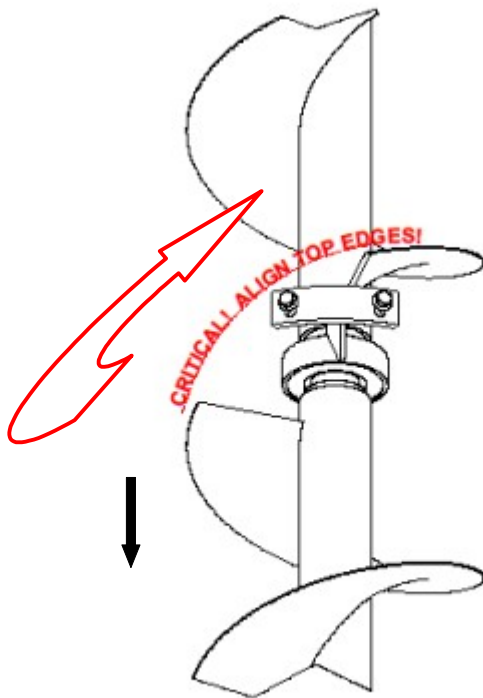


**Fig. 34 BEARING REPLACEMENT  
(Access Covers)**



**Fig. 35 BEARING REPLACEMENT  
(Hanger Bearing)**

## CORRECT TIMING

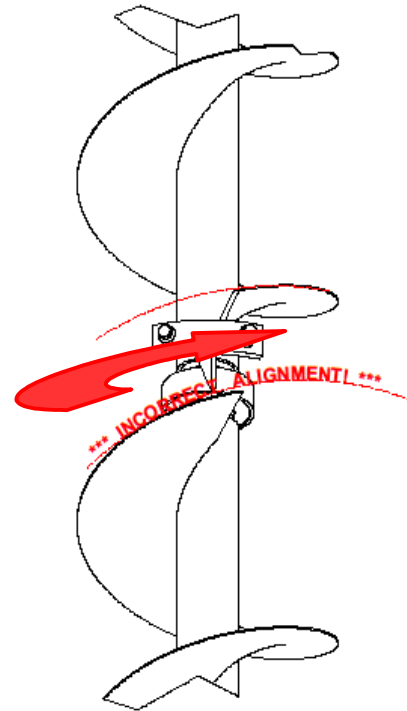


**Fig. 36**

Hanger bearings require the brief interruption of the flighting. Grain still **needs** to **flow** through this area and be picked up by the next flighting section. The hex connecting shafts that engage adjacent flightings allow only six assembly options. Move the lower section all the way up to the hanger bearing and observe the alignment. Ideally you should have the alignment shown in **Fig. 36** by the **red and white arrow** and the phrase **Critical! Align top edges!** If not, slide the section of flighting back down the tube (**black arrow**) enough to clear the hex shaft and rotate the outer edge left or right until you achieve the desired alignment. You will be limited to the six sides and corners of the hex shaft. Move the flighting section back up to the hanger bearing and check again. If you have to be “advanced” a few degrees, that’s **OK**. Grain **needs** to be delivered **ahead** of the next flighting.

Open all access covers and check for proper assembly. The auger capacity and life of the flighting are significantly affected.

## INCORRECT TIMING



**Fig. 37**

When flighting sections are assembled as shown in **Fig. 37**, grain is brought up from below and “**packed**” in **behind** the next flighting section (**solid red arrow**). Again, this reduces capacity, requires more power and increases flighting wear.

Both sections of flighting should be “up to” the hanger bearing, no hex shaft exposed.

If you are the person assembling auger flighting sections and the above alignment happens, **correct it**. If you open access covers and find this, **correct it**.

8. With all sections properly timed, reinstall access covers and tighten mounting bolts to their specified torque.

## 7 TROUBLE SHOOTING

The Sheyenne/Westgo Portable Auger uses rotating flighting to move grain. It is a simple and reliable system that requires minimal maintenance.

In the following section, we have listed many of the problems, causes and solutions to the problems that you may encounter.

If you encounter a problem that is difficult to solve, even after having read through this trouble shooting section, please call your local Sheyenne/Westgo dealer. Before you call, please have this Operator's Manual and the serial number from your machine ready.

<b>PROBLEM</b>	<b>CAUSE</b>	<b>SOLUTION</b>
Auger doesn't turn	Broken shear pin	Replace shear pin
Poor capacity	Flighting sections not timed properly.	Open access covers and check alignment. If incorrect, disassemble and correct per pages 42 and 43.
	Incorrect PTO speed	This auger should operate at 500 RPM. (Over speeding will reduce capacity as much as under speeding).
	Improper Feeding	Intake end should be completely covered with grain
	Worn flighting at intake end	Replace flighting
Auger will not raise	Lift needle valve closed	Open lift needle valve
	Restrictions in hydraulic line	Check hydraulic line for restriction. (This generally occurs at the restrictor valve located next to the hydraulic cylinder)
	Faulty quick couplers on tractor or auger	Replace quick couplers
Auger drops or settles after being positioned	Lift needle valve not closed	Close needle valve after positioning the auger.
	Tractor hydraulic valve faulty	Contact your tractor dealer.

## 8 SPECIFICATIONS

### 8.1 MECHANICAL

<b>Feature</b>	<b>13" - Model 1510</b>
Auger Tube	13 Inch Nominal Outside Diameter
Auger Tube Specifications	12-3/4 O.D. X 12 Ga Wall
Flighting	12" O.D. x 12 Pitch x 5/16" Super Edge
Wheel Size	16.5L -16.1 10 Ply
Tire Pressure	36 psi Max - (Verify w/ Tire Rating)
Reach Arm Tube	6" x 3" x 3/16" Rectangular Tube
Tread Width, Center to Center	157" Narrow / 197" Wide
Hydraulic Cylinder, Qty Two	5 x 48 Chief
Swing Hopper Tire Size	16.5L Drive Wheel, 10" x 2.75" End
Hopper Size	37" x 60" with Dual Auger
Hopper Transport Winch	Fulton
Weight - 90 Foot Model	9,630 Lbs
Weight - 100 Foot Model	10,700 Lbs
Capacity	7,000 to 10,000 Bu / Hr
Power Requirements	1.5 HP / Ft of Length

Specifications subject to change without notice

## 8.2 LIFT DIMENSIONS & AXLE WIDTH CHOICES

Length	Auger Angle	A	B	C
90 Foot	7 Degrees – (Transport / Storage)	42'	11.5'	13'
	30 Degrees	35'	46'	48.5'
	42 Degrees – (Fully Raised)	26'	62'	64.5'
100 Foot	7 Degrees – (Transport / Storage)	52'	13'	15'
	30 Degrees	43'	51'	53.5'
	42 Degrees – (Fully Raised)	33.5'	68'	71'

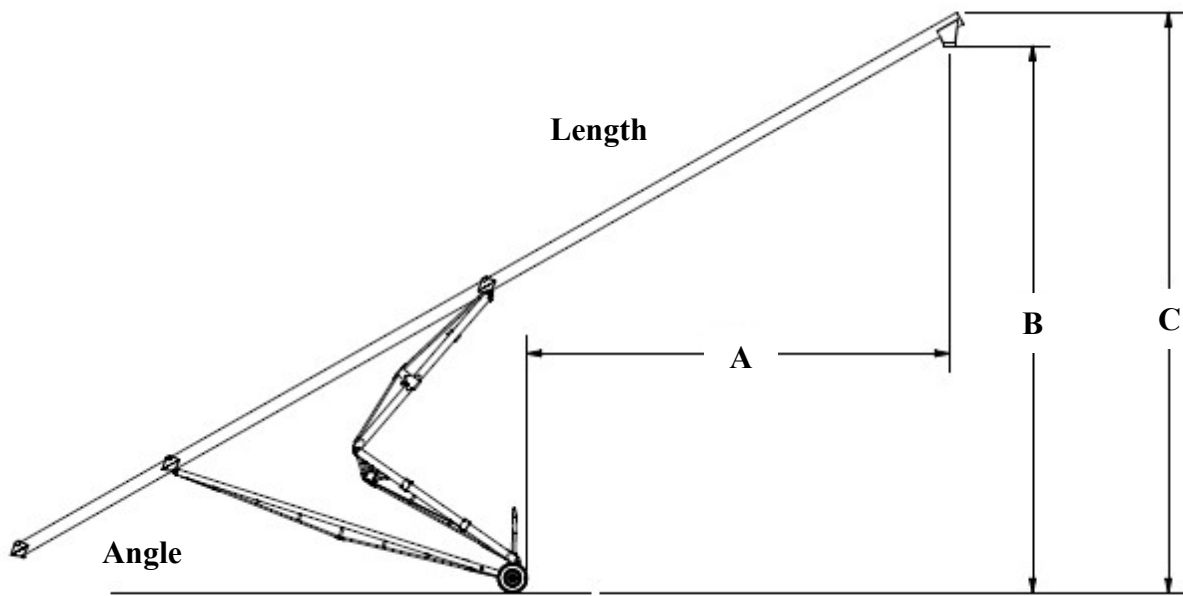
### Axle Width Choices.

#### Outside to Outside

with Floatation Tires:

Narrow for Transport / Storage = 14'- 6"

Wide when Lifted (Raised) = 17'- 6"



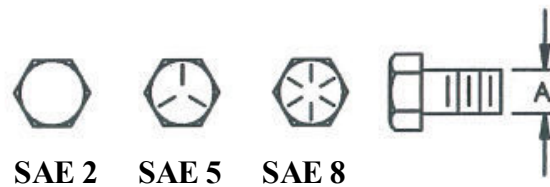
## 8.3 BOLT TORQUE

### CHECKING BOLT TORQUE

The tables shown below give correct torque values for various bolts and capscrews. Tighten all bolts to the torques specified in chart unless otherwise noted. Check tightness of bolts periodically, using bolt torque chart as guide. Replace hardware with the same strength bolt.

### ENGLISH TORQUE SPECIFICATIONS

Bolt Diameter "A"	Bolt Torque*					
	SAE 2		SAE 5		SAE 8	
	N.m	(lb-ft)	N.m	(lb-ft)	N.m	(lb-ft)
1/4"	8	(6)	12	(9)	17	(12)
5/16"	13	(10)	25	(19)	36	(27)
3/8"	27	(20)	45	(33)	63	(45)
7/16"	41	(30)	72	(53)	100	(75)
1/2"	61	(45)	110	(80)	155	(115)
9/16"	95	(70)	155	(115)	220	(165)
5/8"	128	(95)	215	(160)	305	(220)
3/4"	225	(165)	390	(290)	540	(400)
7/8"	230	(170)	570	(420)	880	(650)
1"	345	(225)	850	(630)	1320	(970)



Torque figures indicated above are valid for non-greased or non-oiled threads and heads unless otherwise specified. Therefore, do not grease or oil bolts or capscrews unless specified in this manual. When using locking elements, increase torque values by 5%.

\*Torque value for bolts and capscrews are identified by their head markings.

## NOTES

This page for your use

# PARTS & INDEX SECTION

## TABLE OF CONTENTS

DESCRIPTION	PAGE
Information about the Model 1510 and this section of the manual	50
Hitch and drive systems	51 & 52
Hopper and inclined tube (prior to 7/1/2015)	53 & 54
Hopper, inclined tube and pivot drive assy (after 7/1/2015)	55 & 56
Hopper assembly “ “	57 & 58
Inclined tube assembly “ “	59 & 60
Pivot drive assembly “ “	61 & 62
Transport	63 & 64
Tubes, helicoids and rigid trussing	65 & 66
Hopper Lift Arm (after 5/1/2011)	67
Tractor PTO shaft components	68
Hardware	69
Index	70 - 74



## Model 1510 Auger

These augers are very large in both diameter and length. A picture of a 1510, 13 x 100 in shown on page 5 of this manual. The auger bodies are assembled by sections.

- ▶ The 90 foot auger starts with a 30 foot section at the intake end, adds (2) 20 foot center sections and a 20 foot top section.
- ▶ The 100 foot auger also starts with the same 30 foot section at the intake end, then the (2) 20 foot center sections and a 30 foot top section.

Other features of the Model 1510 auger.

- ▶ Heavy duty transport
  - ▶ Twin lift cylinders
  - ▶ Rigid trussing
  - ▶ Mechanical drive for the hopper and inclined tube
- 

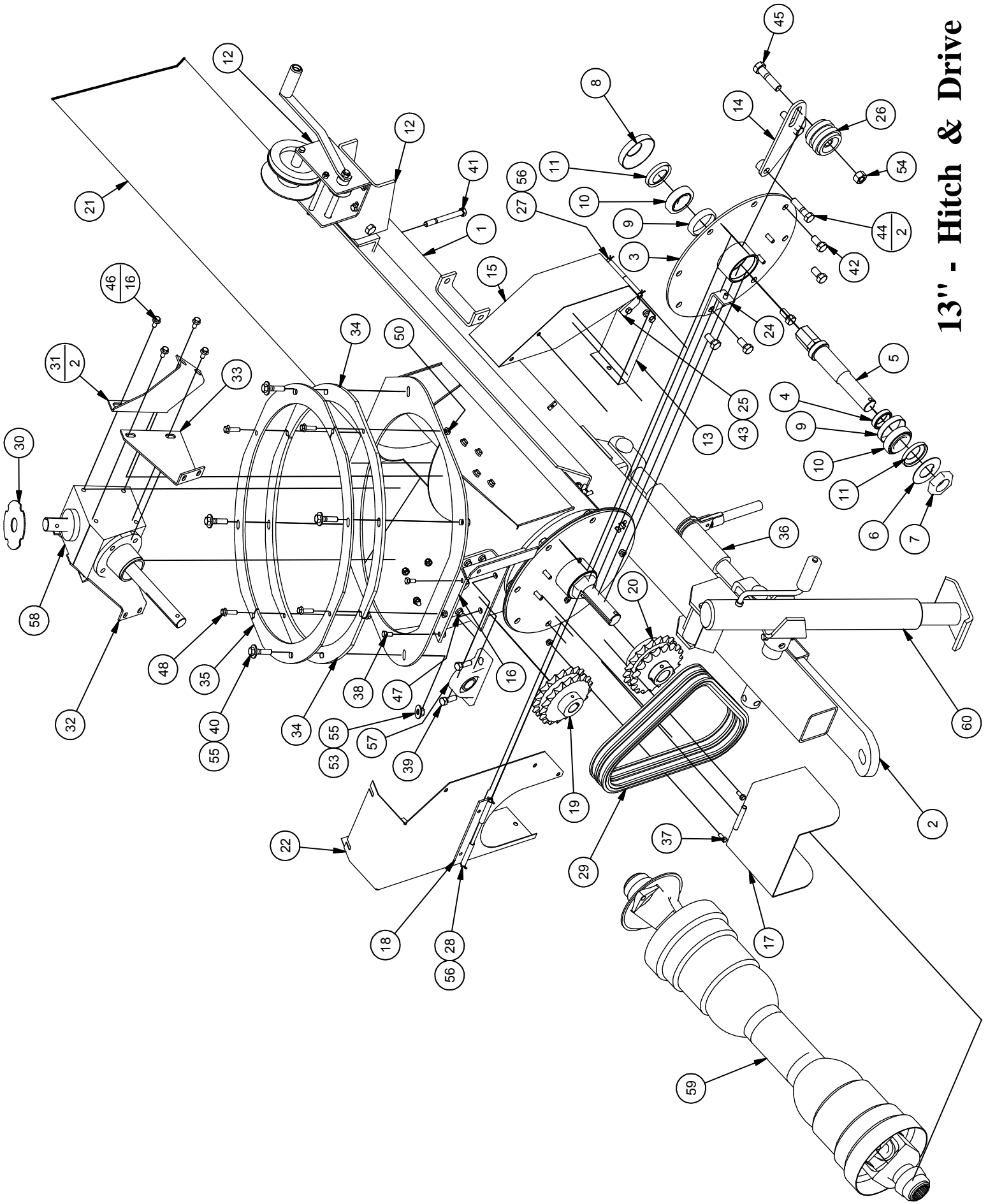
### About this portion of the manual

Producing exploded views of individual augers is a lengthy process. To get reasonable size and clarity we have divided the auger into nine sections. See 51 through 68.

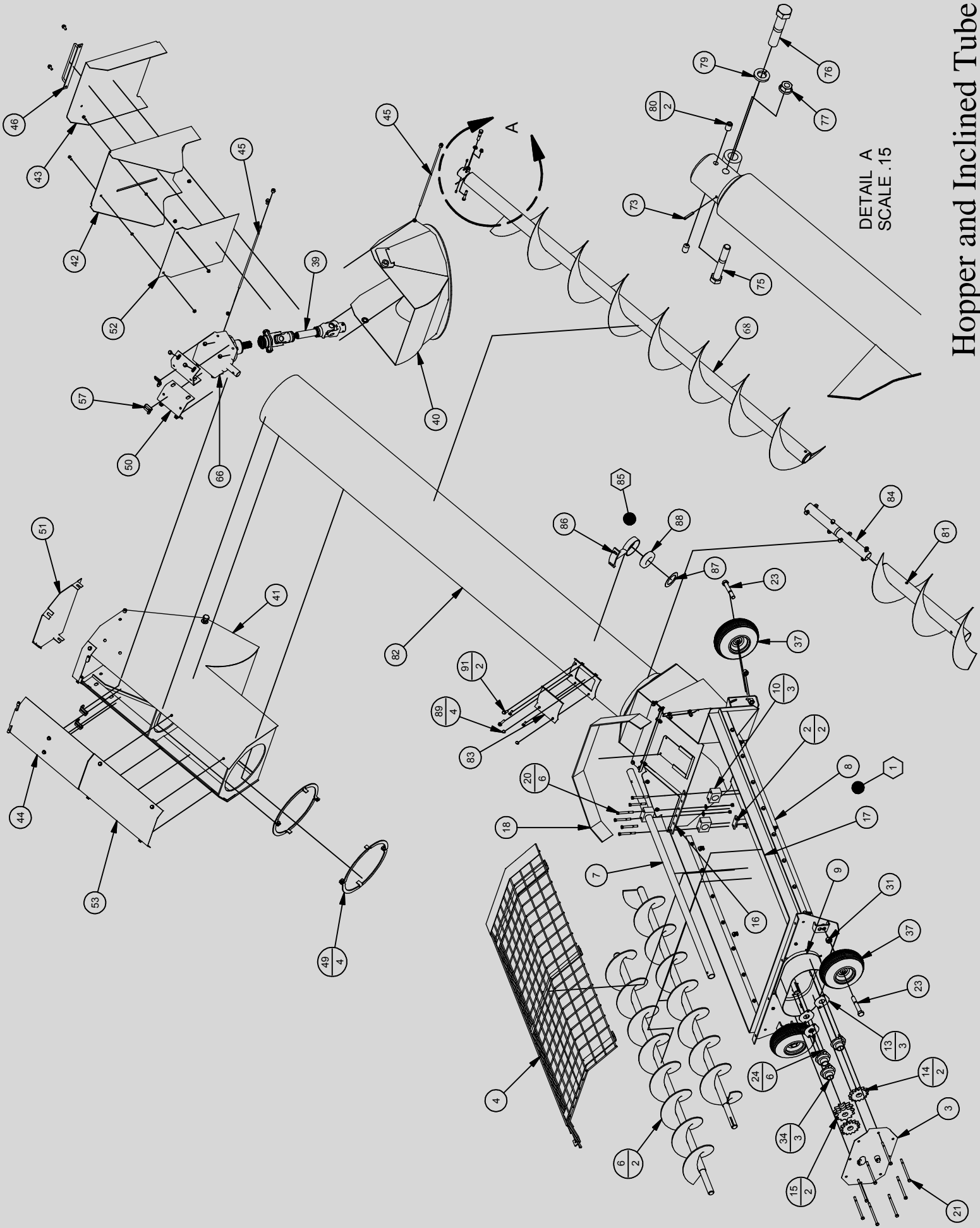
Views on pages 51, 55, 57, 59 and 61 are common to all Model 1510's and some 1410's. The view on page 63 is unique to all Model 1510. The view on page 65 is a 13 x 80 auger. Page 66 distinguishes the parts and part numbers that make 90 and 100 foot augers. All 1510 augers have rigid trussing and heavy duty transport.

On July 1, 2015 the hopper, incline tube and pivot drive were redesigned. Those changes are on pages 55 – 62. The gray pages (53 & 54) are of these assemblies prior to 7/1/2015 and are for service parts.

# 13" - Hitch & Drive



Parts List				Parts List			
ITEM	QTY	PART NUMBER	DESCRIPTION	ITEM	QTY	PART NUMBER	DESCRIPTION
1	1	100-2-2657	TUBE, HITCH	31	2	100-3-5831	GEARBOX SIDE BRACKET
2	1	100-2-2822	HITCH W/A, 13" FRONT	32	1	100-3-5889	GEARBOX END BRACKET, RH
3	1	100-2-2760	BEARING PLATE WELD, 13"	33	1	100-3-5890	GEARBOX END BRACKET, LH
4	1	100-3-4278	COLLAR, TAPERED BEARING	34	2	100-3-5896	PIVOT GUIDE PLATE
5	1	100-3-4282	1-1/2 HEX PTO DR SHAFT, 13"	35	2	100-3-5897	HOLD-DOWN PLATE
6	1	100-3-4283	CAP, LOCKING DUST	36	1	200-2-0705	RATCHET JACK
7	1	100-3-4287	1-3/4-12 PLAIN HEX NUT	37	2	900-01055	5/16NC X 3/4 HEX BOLT G5
8	1	100-3-4291	CAP, DUST	38	9	900-01105	3/8-16 X 3/4 GR 5 HHCS
9	2	901-01301	BEARING CUP, # 25520	39	2	900-01225	1/2NC X 1-1/2 HEX BOLT G5
10	2	901-01311	TAPER BEARING AND CONE, 1.75" ID	40	4	900-01229	1/2NC X 2 HEX BOLT GR5
11	2	901-09220	SEAL # 22334TA	41	4	900-01249	1/2-13 X 5 GR 5 HHCS ZP
12	1	100-2-2925	WINCH & MOUNT ASSY	42	5	900-01339	5/8-11 X 1-1/4 GR 5 HHCS
13	1	100-2-3064	BOTTOM SHIELD WELDMENT	43	1	900-01343	5/8-11 X 1-3/4 GR 5 HHCS
14	1	100-2-3067	IDLER ADJUSTMENT WELDMENT	44	2	900-01349	5/8-11 X 2-1/2 GR 5 HHCS
15	1	100-2-3069	CHAIN GUARD WELDMENT	45	1	900-01411	3/4-10 X 3 GR 5 HHCS
16	1	100-2-3077	SHIELD MOUNT WELDMENT	46	16	900-03436	3/8 X 3/4 SERR FLANGE BOLT GR5
17	1	100-2-3078	PTO SHIELD WELDMENT	47	4	900-03438	3/8-16 x 1 SERR FLG BOLT
18	1	100-2-3079	HINGE WELDMENT	48	4	900-03439	3/8NC X 1-1/4 SERR FLNG BLT
19	1	100-2-3126	SPROCKET 19T 80 1.25 BORE	49	2	900-06137	5/16 NC SERR FLANGE NUT
20	1	100-2-3128	DRIVE SPROCKET WELDMENT	50	22	900-06139	3/8 NC SERR FLANGE NUT
21	1	100-2-3511	1410 13 X 70 TUBE & TRUSS ASSY.	51	6	900-06143	1/2 NC SERR FLANGE NUT
22	1	100-2-4041	CHAIN GUARD W/A	52	8	900-06145	5/8NC SERR FLANGE NUT
23	1	100-3-4287	1-3/4" - 12 NUT	53	4	900-06504	1/2" NC TOPLOCK NUT
24	1	100-3-4826	MOUNT BRACKET	54	1	900-06510	3/4 - 10 TOP LOCK HEX NUT
25	1	100-3-4831	STANDOFF BRACKET	55	8	900-11035	1/2" USS FLATWASHER
26	1	100-3-4838	80-2 IDLER	56	4	900-23023	COTTER PIN, 1/8 X 3/4
27	1	100-3-4841	HINGE PIN	57	1	901-01313	1-1/4 PILLOW BLOCK BRG
28	1	100-3-4844	HINGE PIN	58	1	903-15634	GEARBOX, 668 - 112 DEG. 1:1
29	1	100-3-4933	80-2 x 50 ROLLER CHAIN	59	1	903-18048	PTO SHAFT KIT, DBL CV JOINT
30	1	100-3-5255	TRASH GUARD	60	1	905-23024	5000# POLE JACK WELDMENT



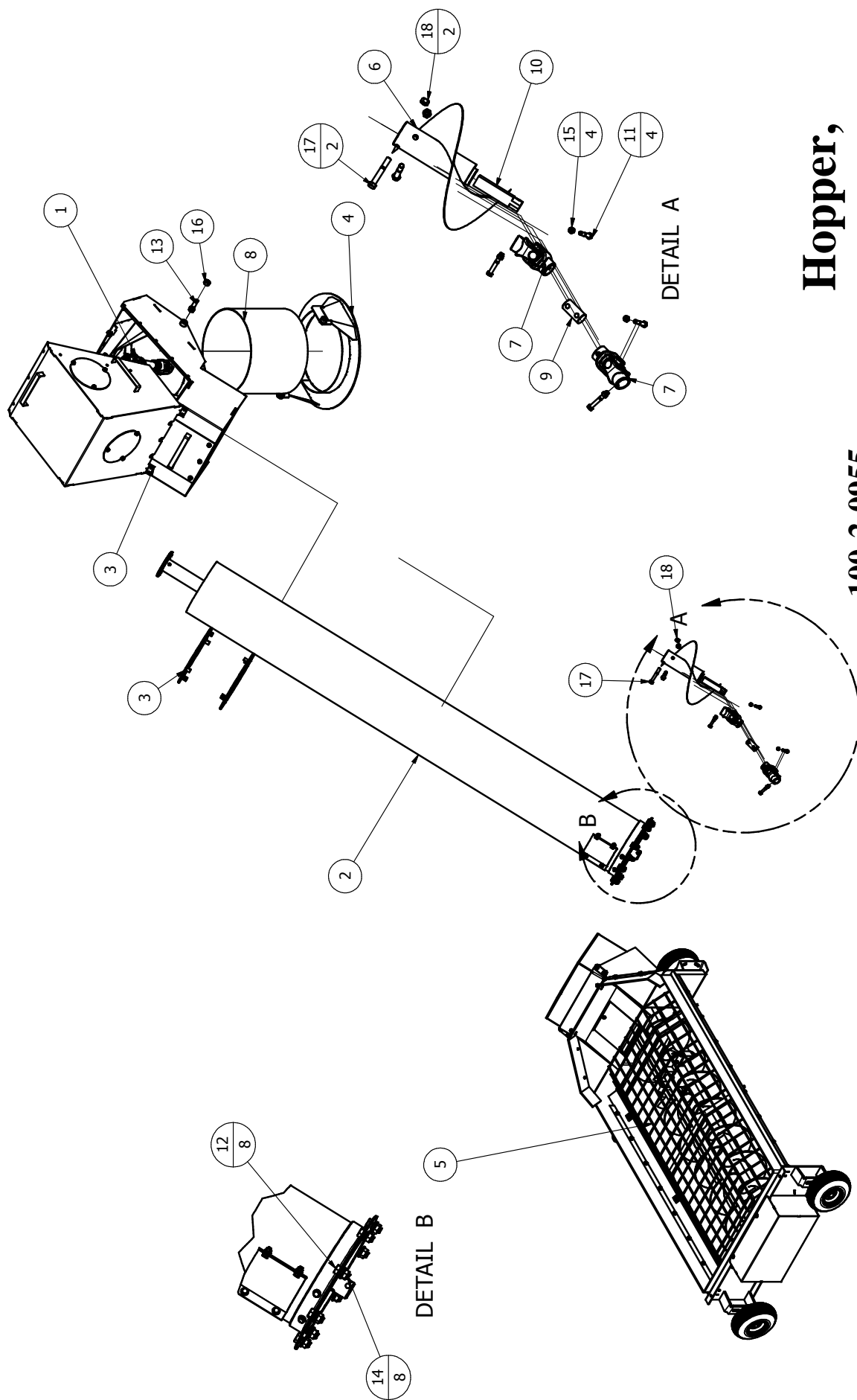
DETAIL A  
SCALE .15

Hopper and Inclined Tube

Parts List				Parts List			
ITEM	QTY	PART NUMBER	DESCRIPTION	ITEM	QTY	PART NUMBER	DESCRIPTION
1	1	100-2-2801	13" MECHANICAL HOPPER ASSY.	48	2	100-3-5512	SPACER WASHER
2	2	100-2-2709	BAR, SPACER	49	4	100-3-5514	SPOUT TUBE CLAMP
3	1	100-2-2747	HOPPER, END PLATE W/A	50	2	100-3-5839	UPPER GEARBOX BRACKET
4	1	100-2-2798	MESH WELD, 13" SWIVEL HOPPER	51	1	100-3-5885	SPOUT END COVER
5	1	100-2-2800	HINGE WELDMENT, 13"	52	1	100-3-5873	PIVOT INSIDE SHIELD
6	2	100-2-2804	HOPPER HELICOID W/A	53	1	100-3-5874	INCLINE SPOUT COVER
7	1	100-2-2806	DRIVER SHAFT W/A	54	2	100-3-5882	PIVOT DOOR PIN CAP
8	1	100-2-2807	HOPPER WELD, 13" MECH	55	2	100-3-5887	HINGE PIN CAP
9	1	100-3-3510	GASKET, 8" HEAD COVER	56	2	100-3-5891	DOOR SLIDE BUSHING
10	3	100-3-3675	1-1/2 SPLIT WOOD BEARING	57	4	100-3-5899	SPRING MOUNT ANGLE
11	1	100-3-4109	TAB, LIFT HOPPER	58	2	900-01055	5/16NC X 3/4 HEX BOLT G5
12	1	100-3-4334	HINGE STOP, 13"	59	2	900-01407	3/4-10 X 2-1/2 GR 5 HHCS
13	3	100-3-4371	GASKET, 1-1/4" 2 HOLE	60	4	900-03419	5/16-18 X 3/4 SERR FLNG BOLT
14	2	100-3-4465	SPROCKET, 60B15 - 1.25B	61	14	900-03436	3/8 X 3/4 SERR FLANGE BOLT GR5
15	2	100-3-4468	SPROCKET, 60B11 - 1.25B	62	6	900-03438	3/8-16 x 1 SERR FLG BOLT
16	1	100-3-4942	MOUNT, SPLIT BRG-13"	63	6	900-06137	5/16 NC SERR FLANGE NUT
17	1	100-3-5340	RUBBER STRIP, 13" HOPPER	64	12	900-06139	3/8 NC SERR FLANGE NUT
18	1	100-3-5341	RUBBER STRIP, TOP	65	2	900-06510	3/4 - 10 TOP LOCK HEX NUT
19	4	900-01059	5/16NC X 1 HEX BOLT G5	66	1	903-15633	GEARBOX, 668 - 68 DEG. 1:1
20	6	900-01129	3/8NC X 3-1/2 HEX BOLT GR5	67	1	100-2-3576	INCLINE TUBE ASSY 13" MD
21	8	900-01141	3/8NC X 8 HEX BOLT GR5	68	1	100-2-3247	INCLINED HELICOID WELDMENT
22	2	900-01221	1/2NC X 1 HEX BOLT GR5	69	1	100-2-3248	TUBE WELDMENT
23	4	900-01423	3/4-10 X 5 GR 5 HHCS	70	1	100-2-3597	END COUPLER WELD, 13"
24	6	900-01694	3/8NC X 3/4 CARRIAGE BOLT	71	1	100-3-3292	TUBE
25	30	900-03438	3/8-16 x 1 SERR FLG BOLT	72	1	100-3-5886	COUPLER, NEW
26	6	900-03439	3/8NC X 1-1/4 SERR FLANGE BOLT	73	1	900-29082	1/8 X 3/4 ROLL PIN
27	4	900-06137	5/16 NC SERR FLANGE NUT	74	1	100-3-4467-88.94	5/16 SUPEREDGE FLIGHTING
28	36	900-06139	3/8 NC SERR FLANGE NUT	75	1	900-01121	3/8 NC X 2.5 HEX BOLT G5
29	12	900-06500	3/8 TOPLOCK NUT - UNC	76	1	900-01233	1/2-13 X 2-1/2 GR 5 HHCS ZP
30	2	900-06504	1/2" NC TOPLOCK NUT	77	1	900-06139	3/8 NC SERR FLANGE NUT
31	8	900-06510	3/4 - 10 TOP LOCK HEX NUT	78	1	900-06143	1/2 NC SERR FLANGE NUT
32	18	900-11033	3/8 USS FLATWASHER	79	1	900-11013	1/2" SPLIT LOCK WASHER
33	3	900-27024	1/4 X 1 WOODRUFF KEY #808	80	2	900-16361	5/16 NC X 1/2 SET SCREW CUP PT
34	3	901-01101	1-1/4 ECONOMOUNT BEARING	81	1	100-2-3364	INTAKE HELICOID, NEW
35	1	905-01159	HEX BUSHING, 1/2MPT X 1/8FPT	82	1	100-2-3577	INCLINED TUBE WELDMENT
36	1	905-03080	VENT PLUG, 1/8" NPT	83	1	100-3-1113	COVER, ACCESS 13"
37	4	905-09134	TIRE ASSY, HOPPER	84	1	100-3-4000	CONNECTOR SHAFT
38	1	100-2-3575	PIVOT DRIVE ASSY., 13" M.D.	85	1	106-2-0711	13" HANGER BEARING ASSY
39	1	100-2-3336	MECH. DRIVE LINE ASSY., 13"	86	1	106-2-0710	13" HANGER BRG SUBWELD
40	1	100-2-3566	LOWER PIVOT W/A	87	1	900-11129	2-1/2 WIDE RIM MACH BUSHING
41	1	100-2-3568	INCLINE SPOUT W/A	88	1	901-01079	2" INSERT BEARING
42	1	100-2-3584	INSIDE PIVOT DOOR W/A	89	4	900-01055	5/16NC X 3/4 HEX BOLT G5
43	1	100-2-3585	OUTSIDE PIVOT DOOR W/A	90	4	900-01241	1/2-13 x 3-1/2 GR 5 HHCS
44	1	100-2-3586	OVERFLOW DOOR W/A	91	2	900-03439	3/8NC X 1-1/4 SERR FLANGE BOLT
45	2	100-2-3587	PIVOT DOOR PIN W/A	92	4	900-06137	5/16 NC SERR FLANGE NUT
46	1	100-2-3588	PIVOT DOOR HANDLE W/A	93	2	900-06139	3/8 NC SERR FLANGE NUT
47	1	100-3-4844	HINGE PIN	94	4	900-06504	1/2" NC TOPLOCK NUT

For service parts: 100-2-1801 Hopper  
 Introduced about 9/1/2010 Incline  
 Ran to 7/1/2015 100-2-3536 Incline  
 100-2-3575 Pivot Drive

# Hopper and Incline Tube



# Hopper, Incline Tube, Pivot Drive

- 100-2-0955
- 100-2-4042
- 100-2-4000
- 100-2-4028

DETAIL B

DETAIL A

PARTS LIST			
ITEM	QTY	PART NUMBER	DESCRIPTION
1	1	100-2-3336	DRIVESHAFT, VERTICAL PTO - 13"
2	1	100-2-4000	INCLINE TUBE ASSEMBLY
3	1	100-2-4028	PIVOT DRIVE ASSY., 13" M.D. 2015
4	1	100-2-4035	LOWER PIVOT W/A
5	1	100-2-4042	13" MECHANICAL HOPPER ASSY.
6	1	100-2-4048	HELICOID, TRANSITION - SHORT
7	2	100-3-2485	1-1/4" - 1-1/4" U JOINT
8	1	100-3-6305	18" CLEAR FLEX TUBE
9	1	100-5-1217	TUBE, FIXED CONNECTOR
10	1	100-5-1222	SHAFT 1-3/16 SQ
11	4	900-01121	3/8 NC X 2.5 HEX BOLT G5
12	8	900-01339	5/8-11 X 1-1/4 GR 5 HHCS
13	2	900-01407	3/4-10 X 2-1/2 GR 5 HHCS
14	8	900-06145	5/8NC SERR FLANGE NUT
15	4	900-06500	3/8 TOPLOCK NUT- UNC
16	2	900-06510	3/4 - 10 TOP LOCK HEX NUT
17	2	900-01241	1/2-13 x 3-1/2 GR 5 HHCS
18	2	900-06504	1/2" NC TOPLOCK NUT

# Hopper, Incline Tube, Pivot Drive

Note: Items 5, 2 & 3 will be 'exploded'  
on the next (6) pages.

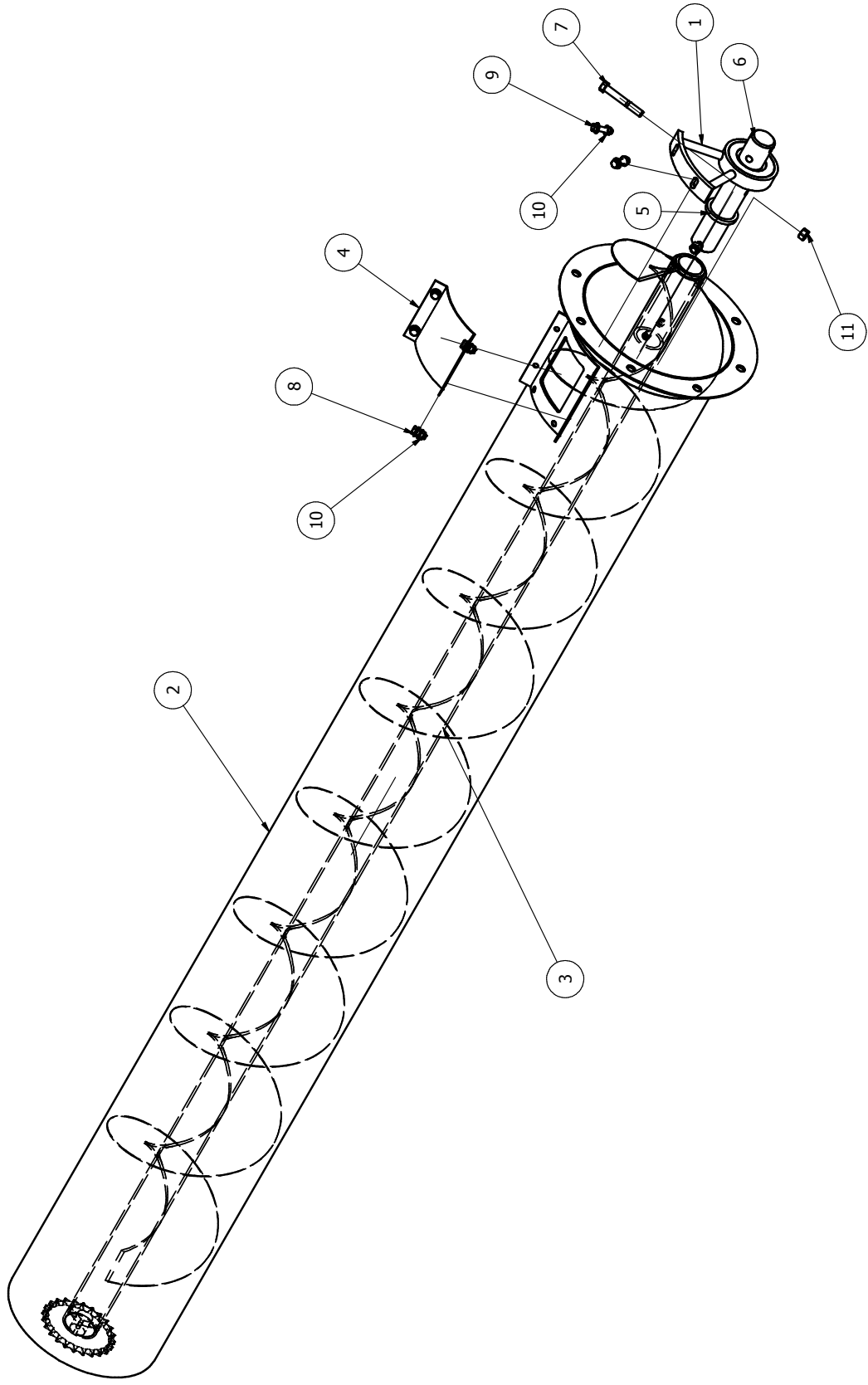




PARTS LIST			
ITEM	QTY	PART NUMBER	DESCRIPTION
1	2	100-2-2709	BAR, SPACER
2	1	100-2-2800	HINGE WELDMENT, 13"
3	1	100-2-3971	HOPPER LIFT W/A
4	1	100-2-4026	CHAIN GUARD 13" HOPPER
5	1	100-2-4043	HOPPER WELD, 13" MECH
6	1	100-2-4044	LH HELICOID, LH FLIGHTING - 13" HOPPER
7	1	100-2-4045	RH HELICOID, RH FLIGHTING - 13" HOPPER
8	1	100-2-4046	MESH WELD, 13" SWIVEL HOPPER
9	3	100-3-3675	1-1/2 SPLIT WOOD BEARING
10	2	100-3-6374	#60 18T 1.25B SPROCKET
11	2	100-3-4468	11T #60 1.25" SPROCKET
12	1	100-3-4942	MOUNT, SPLIT BRG-13"
13	1	100-3-5340	RUBBER STRIP, 13" HOPPER
14	1	100-3-5341	RUBBER STRIP, TOP
15	1	100-3-6190	COVER, HOPPER HINGE
16	2	100-3-6300	12T #60 IDLER SPROCKET
17	1	100-3-6364	DRIVESHAFT
18	1	100-3-6365	TRANSITION STOP 2015
19	1	900-01053	5/16NC X 5/8 HEX BOLT G5 ZP
20	6	900-01129	3/8NC X 3-1/2 HEX BOLT GR5
21	2	900-01221	1/2NC X 1 HEX BOLT GR5
22	2	900-01345	5/8 x 2 HEX BOLT GR5
23	4	900-01423	3/4-10 X 5 GR 5 HHCS
24	2	900-03436	3/8 X 3/4 SERR FLANGE BOLT GR5
25	28	900-03438	3/8-16 x 1 SERR FLG BOLT
26	8	900-03439	3/8NC X 1-1/4 SERR FLNG BLT
27	30	900-06139	3/8 NC SERR FLANGE NUT
28	6	900-06145	5/8NC SERR FLANGE NUT
29	12	900-06500	3/8 TOPLOCK NUT- UNC
30	2	900-06504	1/2" NC TOPLOCK NUT
31	18	900-11033	3/8 USS FLATWASHER
32	6	900-11037	5/8 USS FLATWASHER ZP
33	3	901-01357	1-1/4 FLANGE BEARING
34	4	905-09134	TIRE ASSY, HOPPER

# 13" Hopper Assy

100-2-4042



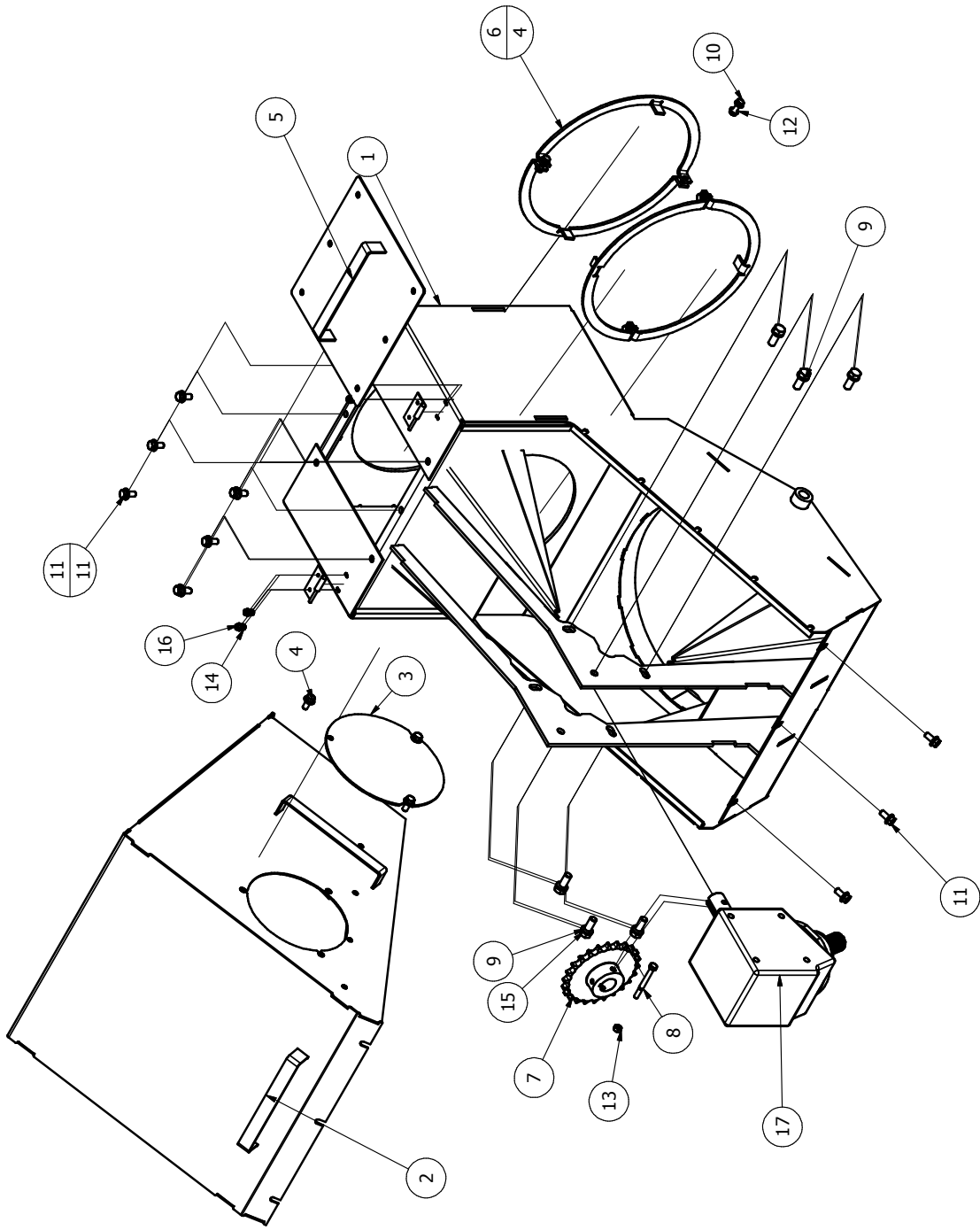
# Incline Tube Assy

100-2-4000

PARTS LIST			
ITEM	QTY	PART NUMBER	DESCRIPTION
1	1	100-2-3705	13" HANGER BEARING ASSY
2	1	100-2-4001	INCLINED TUBE WELDMENT
3	1	100-2-4002	INCLINED HELICOID WELDMENT
4	1	100-3-1113	COVER, ACCESS 13"
5	1	100-3-6369	BEARING SPACER INCLINE
6	1	100-5-1221	SHAFT, STUB - INCLINE
7	2	900-01241	1/2-13 x 3-1/2 GR 5 HHCS
8	4	900-03436	3/8 X 3/4 SERR FLANGE BOLT GR5
9	2	900-03439	3/8NC X 1-1/4 SERR FLNG BLT
10	6	900-06139	3/8 NC SERR FLANGE NUT
11	2	900-06504	1/2" NC TOPLOCK NUT

# Incline Tube Assy

100-2-4000



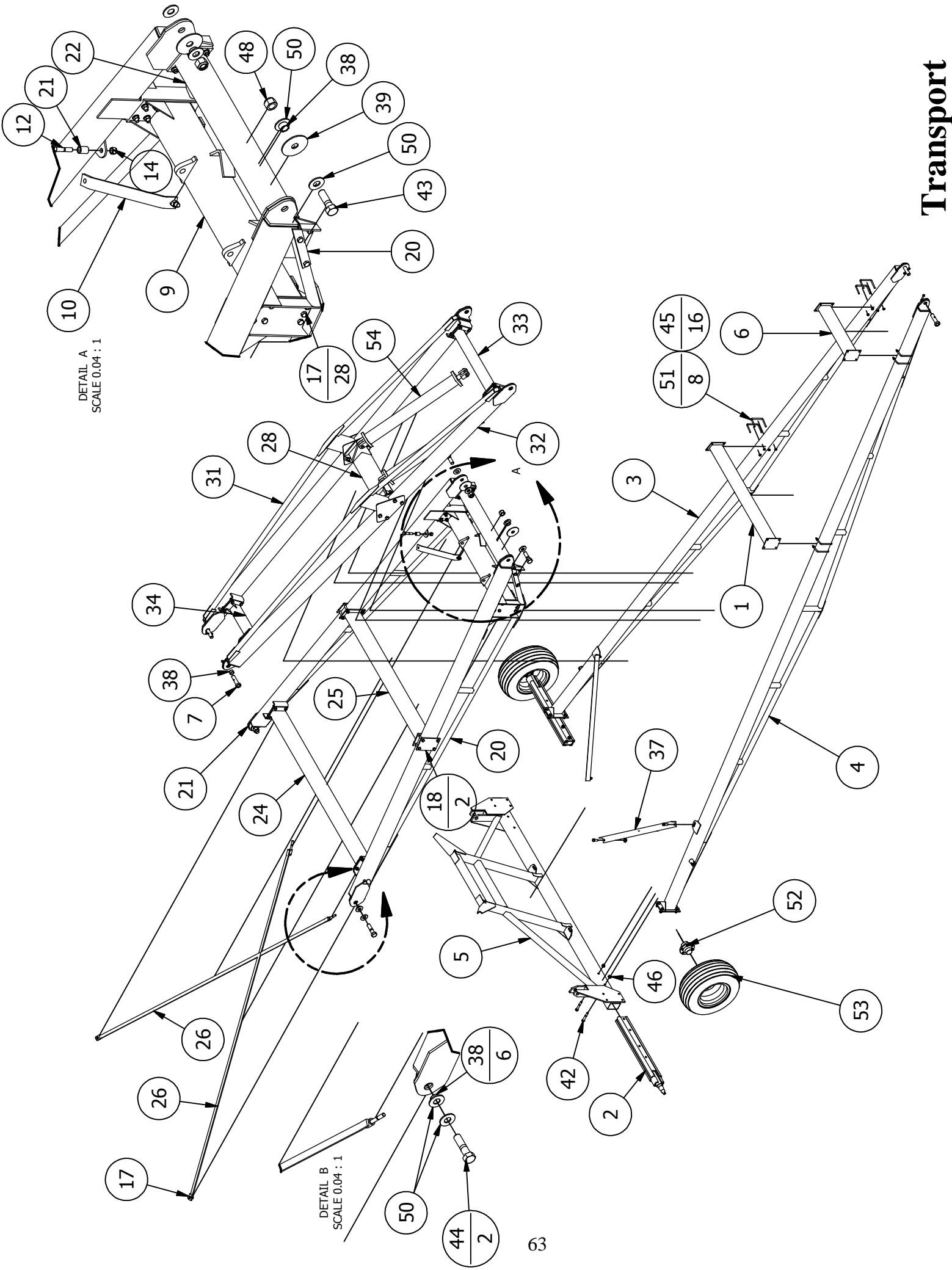
# Pivot Drive Assy

100-2-4028

PARTS LIST			
ITEM	QTY	PART NUMBER	DESCRIPTION
1	1	100-2-4029	INCLINE SPOUT W/A
2	1	100-2-4030	SPOUT DOOR, 13"
3	3	100-3-6329	SPOUT ACCESS DOOR, 13"
4	9	900-03436	3/8 X 3/4 SERR FLANGE BOLT GR5
5	1	100-2-4033	INCLINE SPOUT COVER
6	4	100-3-5514	SPOUT TUBE CLAMP
7	1	100-3-6344	MACHINED SPROCKET #60 24T 1.25" BORE
8	1	900-01075	5/16NC X 3 HEX BOLT
9	6	900-01223	1/2-13 X 1-1/4 GR 5 HHCS
10	4	900-03419	5/16-18 X 3/4 SERR FLNG BOLT
11	11	900-03436	3/8 X 3/4 SERR FLANGE BOLT GR5
12	4	900-06137	5/16 NC SERR FLANGE NUT
13	1	900-06498	5/16NC HEX TOPLOCK NUT
14	4	900-06578	10-24 NYLON LOCK NUT
15	6	900-11013	1/2" SPLIT LOCK WASHER
16	4	900-17602	10-24 x 3/4" FLNGE HEX HD
17	1	903-15633	GEARBOX, 668 - 68 DEG. 1:1

# Pivot Drive Assy

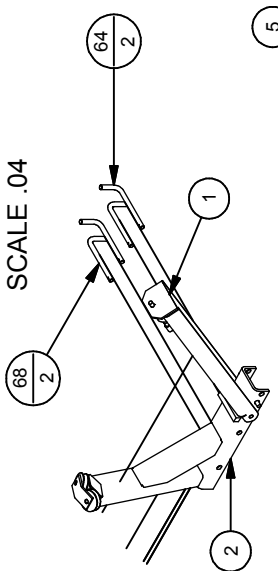
100-2-4028



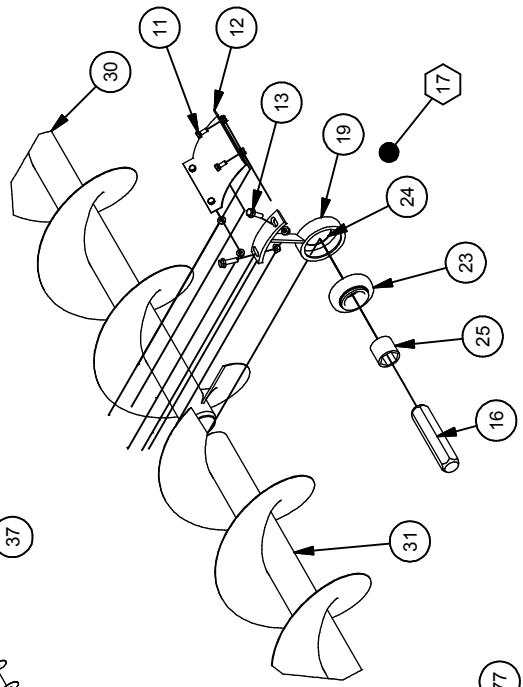
PARTS LIST				PARTS LIST			
ITEM	QTY	PART NUMBER	DESCRIPTION	ITEM	QTY	PART NUMBER	DESCRIPTION
1	1	100-2-3383	REACH ARM BRACE W/A	28	1	100-2-3517	UPPER CYL MOUNT W/A
2	2	100-2-3420	AXLE EXTENSION	29	8	900-01535	1"NC X 6 HEX BOLT G5
3	1	100-2-3512	REACH ARM WELD, RH	30	8	900-06598	1" NC NYLON LOCKNUT
4	1	100-2-3513	REACH ARM WELD, LH	31	1	100-2-3612	UPPER LIFT ARM W/A, LH
5	1	100-2-3525	AXLE WELDMENT	32	1	100-2-3613	UPPER LIFT ARM W/A, RH
6	1	100-2-3528	REACH ARM BRACE W/A	33	1	100-2-3615	CROSS BRACE W/A X 39.33 IN
7	4	100-2-3529	PIVOT PIN WELDMENT	34	1	100-2-3616	CROSS BRACE W/A X 20.36 IN
8	1	100-2-3608	LOWER LIFT ARM ASSY	35	16	900-06147	3/4 - 10 FLANGE NUT
9	1	100-2-3521	LOWER CYL MOUNT WELDMENT	36	16	900-01403	3/4NC X 2 HEX BOLT GR5
10	2	100-3-5754	BRACE BAR	37	2	100-3-5555	ANGLE BRACE
11	2	900-01475	7/8" x 3" NC GR5 BOLT	38	6	100-3-5744	PIVOT BUSHING, 1.06 IN
12	2	900-01481	7/8 NC X 4-1/2 HEX BOLT G5 ZP	39	2	100-3-5970	WASHER, 1/4 X 6 X 1.53
13	4	900-11039	7/8 USS FLAT WASHER ZP	40	4	900-01241	1/2-13 x 3-1/2 GR 5 HHCS
14	4	900-06596	7/8 Std NC Nylock Nut	41	12	900-01403	3/4NC X 2 HEX BOLT GR5
15	2	900-01429	3/4 X 6-1/2 HEX BOLT GR5 ZP	42	4	900-01423	3/4-10 X 5 GR 5 HHCS
16	42	900-06147	3/4 - 10 FLANGE NUT	43	2	900-01630	1-1/2 - 6 X 5 HHCS GR 5 ZP
17	28	900-01403	3/4NC X 2 HEX BOLT GR5	44	2	900-01632	1-1/2 - 6 X 6 HHCS GR 5 ZP
18	2	100-3-5903	CROSS BRACE MOUNT PLATE	45	16	900-06143	1/2 NC SERR FLANGE NUT
19	8	900-01423	3/4-10 X 5 GR 5 HHCS	46	16	900-06147	3/4 - 10 FLANGE NUT
20	1	100-2-3610	LOWER LIFT ARM W/A, RH	47	5	900-06504	1/2" NC TOPLOCK NUT
21	1	100-2-3611	LOWER LIFT ARM W/A, LH	48	4	900-06604	1 1/2 Std NC Nylock Nut
22	1	100-2-3614	CROSS BRACE W/A	49	4	900-11038	3/4 USS FLAT WASHER
23	4	900-01425	3/4-10 X 5-1/2 GR 5 HHCS	50	12	900-11044	1-1/2 USS FLAT WASHER
24	1	100-2-3617	CROSS BRACE W/A X 100.92"	51	8	900-31082	U-BOLT, 1/2NC X 6 X 4-1/2 LONG
25	1	100-2-3618	CROSS BRACE W/A	52	2	905-09004	HUB ASSEMBLY
26	2	100-2-3619	TRUSS BAR W/A	53	2	905-09079	WHEEL & TIRE ASSEMBLY
27	1	100-2-3609	UPPER LIFT ARM ASSY	54	2	905-21224	HYD. CYL. 5 X 48 PRINCE

# Tubes, Helicoids & Trussing

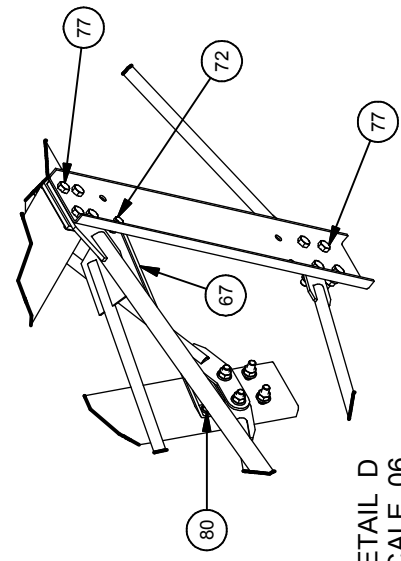
DETAIL B  
SCALE .04



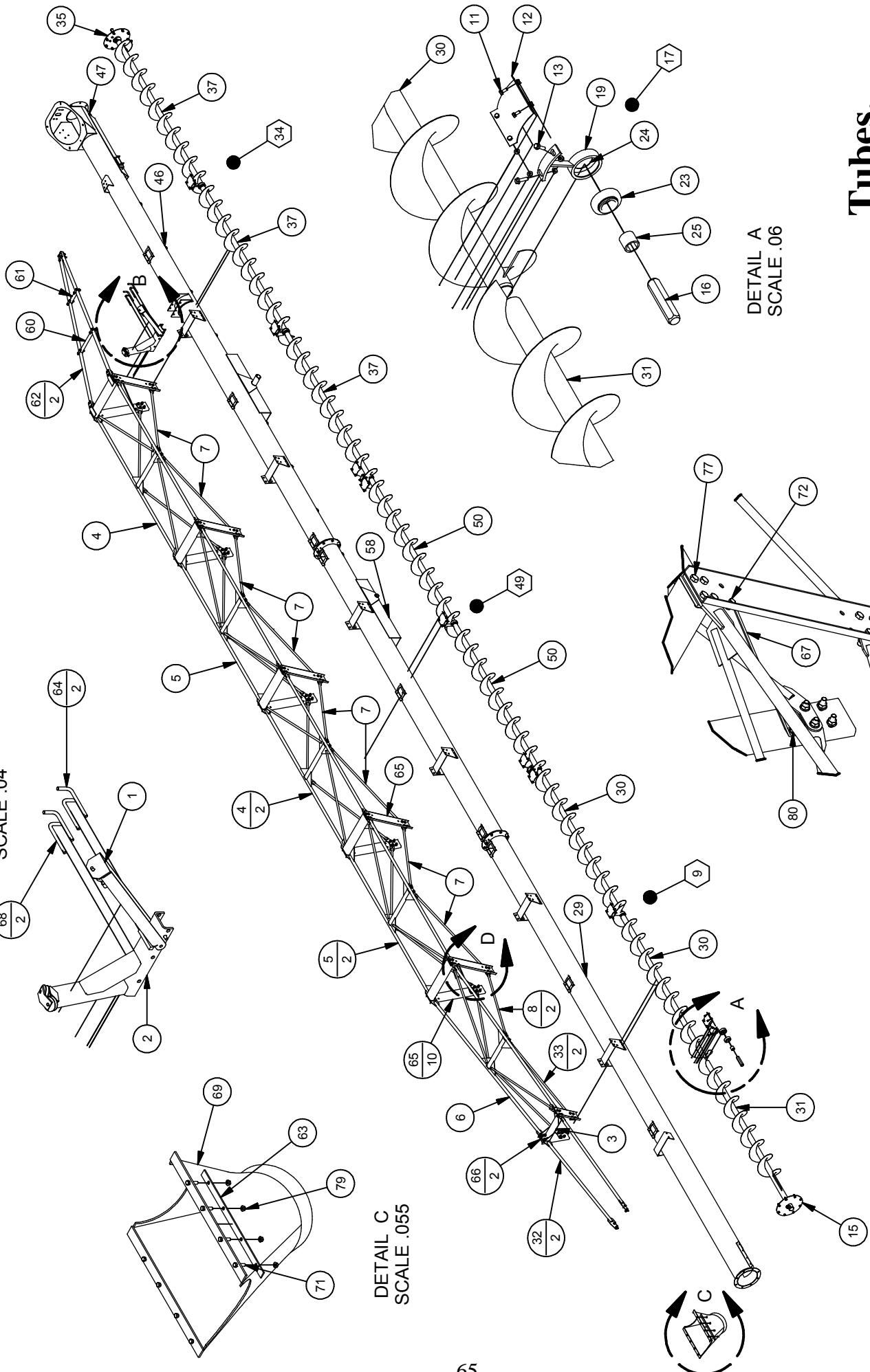
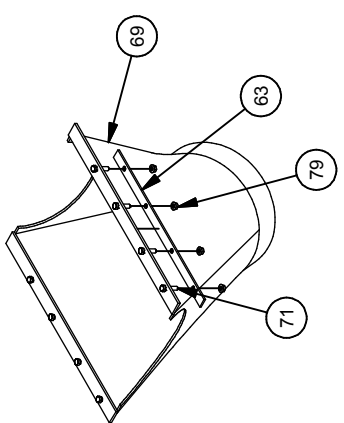
DETAIL A  
SCALE .06



DETAIL D  
SCALE .06



DETAIL C  
SCALE .055





## Parts List

Item	Qty	Part Number	Description
1	1	100-2-2843	Hopper lift arm weld, 13"
2	1	100-2-2874	Lift arm mount weld, 13"
3	1	100-2-3089	End truss cross brace weld, 13"
4	2	100-2-3316	Truss weld, outside – 13"
5	2	100-2-3320	Truss weld, inside – 13"
6	1	100-2-3321	End truss weld, 13"
7	16	100-2-3534	Truss weld, 58.50" long pipe
8	2	100-2-3535	Truss weld, 54.85" long pipe
9	1	100-2-3559	Top tube assy, 13" - 20' – for 90' auger
9	1	100-2-3638	Top tube assy, 13" - 30' – for 100' auger
10	AR	900-06137	5/16NC serrated flange nut
11	AR	900-01055	5/16 x 3/4 Hex bolt, Gr 5
12	AR	100-3-1113	Cover, access – 13"
13	AR	900-03439	3/8NC x 1-1/4 serrated flange bolt
14	AR	900-06139	3/8NC serrated flange nut
15	1	100-2-2680	Top plate assy, 13"
16	AR	100-3-4209	1-1/2 Hex connecting shaft
17	AR	106-2-0712	Hanger bearing assy, hex-13"-complete
18	-	106-2-0711	Hanger bearing assy, hex – 13"
19	AR	106-2-0710	Hanger bearing subweld, hex – 13"
23	AR	901-01079	2" bearing insert
24	AR	900-11129	2-1/2 machine bushing, wide rim
25	AR	100-3-4208	Bushing, hex – 13"
26	AR	900-01341	5/8NC x 1-1/2 hex bolt, Gr 5
27	AR	900-06508	5/8NC hex nut, top lock
28	AR	900-01361	5/8NC x 4 hex hd cap screw, Gr 5
29	1	100-2-3560	Top tube weld, 13" - 20' – for 90' auger
29	1	100-2-3539	Top tube weld, 13" - 30' – for 100' auger
30*	AR	100-2-2818	Center helicoid weld, 13" - common
31	1 ea	100-2-2819	Top helicoid weld, 13" - common
32	2	100-2-3555	End Truss weld, 68.52" long pipe
33	2	100-2-3564	Truss weld, 55.27" long pipe
34	1 ea	100-2-3544	Bottom tube assy, 13"-30" - common
35	1	100-2-2824	Bearing plate assy, 13"

AR - As required

Yellow background highlighting indicates parts that vary between 90 and 100 foot models

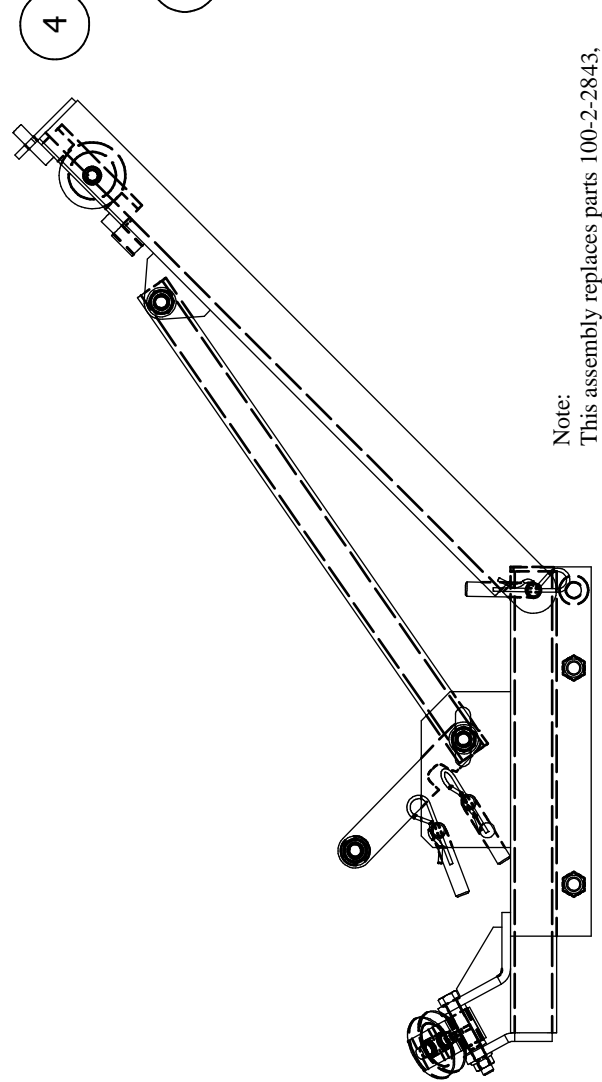
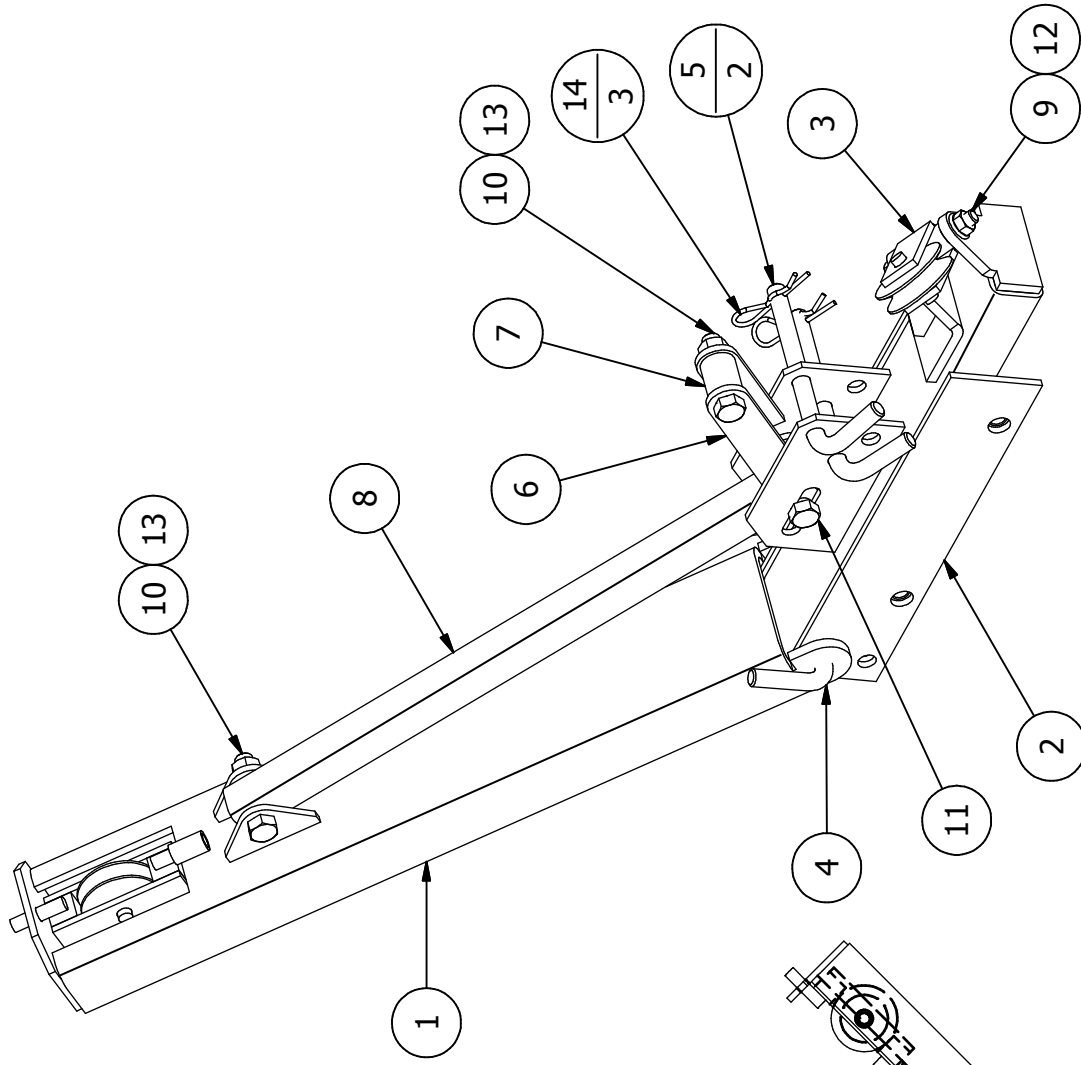
\* Balloons with the numbers 30, 37 & 50 are all the same part

## Parts List

Item	Qty	Part Number	Description
46	1 ea	100-2-3571	Bottom tube weld, 13"-30" - common
47	1	100-2-3574	Clean-out door weld, 13"
48	2	900-01063	5/16-18 x 1-1/2 Hex hd cap screw, Gr 5
49	1 ea	100-2-3540	Lower center tube assy, 13" - 20' - common
49**	1 ea	100-2-3542	Upper center tube assy, 13" - 20' - common
58	1 ea	100-2-3541	Lower center tube weld, 13" - 20' - common
58**	1 ea	100-2-3543	Upper center tube weld, 13" - 20' - common
59	1	100-2-3578	End cross channel weld, 13"
60	1	100-2-3579	Cross brace weld, long
61	1	100-2-3580	Cross brace weld, short
62	2	100-2-3583	Lower end truss weld
63	2	100-3-3864	Bar, spout
64	2	100-3-4747	Pin, hopper arm mounting – 13"
65	10	100-3-4846	Truss standoff channel
66	2	100-3-4662	Truss standoff, short
67	2	100-3-4938	Truss brace bar
68	2	100-3-5258	Hopper arm mount pin
69	1	100-3-5377	13" discharge spout, drilled
70	4	100-3-5856	Cross tube mount tab
71	8	900-01113	3/8NC x 1-1/2 hex bolt Gr 5
72	4	900-01221	1/2NC x 1" hex bolt Gr 5
73	8	900-01233	1/2-13NC x 2-1/2 hex hd cap screw Gr 5 Zp
74	8	900-01237	1/2-13NC x 3 hex hd cap screw Gr 5
75	12	900-01337	5/8NC x 1" hex hd cap screw
76	AR	900-01341	5/8NC x 1-1/2 hex bolt Gr 5
77	92	900-01345	5/8 x 2 hex bolt Gr 5
78	6	900-01363	5/8-11NC x 4-1/2 hex hd cap screw Gr 5 Zp
79	AR	900-06139	3/8NC serrated flange nut
80	AR	900-06143	1/2NC serrated flange nut
81	AR	900-06145	5/8NC serrated flange nut

\*\* The second 49 and 58 are not shown on the exploded view

PARTS LIST			
ITEM	QTY	PART NUMBER	DESCRIPTION
1	1	100-2-3131	HOPPER LIFT ARM WELD, 13"
2	1	100-2-3604	LIFT ARM MOUNT W/A, 13"
3	1	100-2-3605	PULLEY SUBWELD
4	1	100-3-4747	PIN, HOPPER ARM MTG, 13"
5	2	100-3-5258	HOPPER ARM MOUNTING PIN
6	2	100-3-5945	LATCH BAR
7	1	100-3-5946	HANDLE TUBE
8	1	100-3-5949	HOPPER LIFT ARM LOCK TUBE
9	1	900-01241	1/2-13 x 3-1/2 GR 5 HHCS
10	2	900-01353	5/8-11 X 3 HHCS
11	1	900-01357	5/8-11 X 3-1/2 GR 5 HHCS
12	1	900-06143	1/2 NC SERR FLANGE NUT
13	3	900-06145	5/8NC SERR FLANGE NUT
14	3	900-25005	R HITCH PIN #9

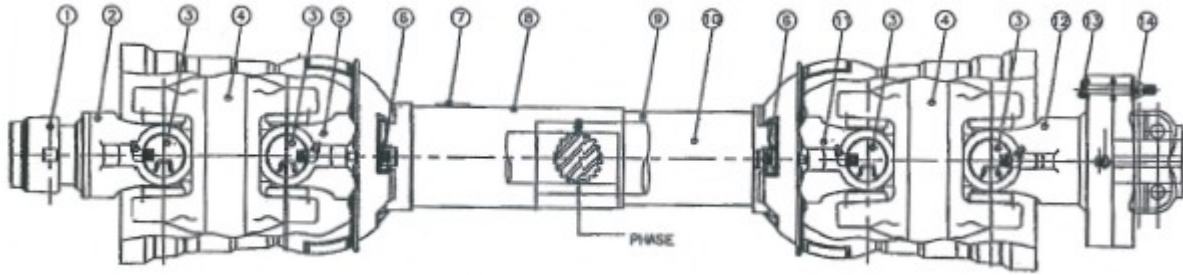


Note:  
 This assembly replaces parts 100-2-2843,  
 100-2-2874 and hardware on 13" 1510 augers.  
 See items 1 and 2 on pages 65 and 66.

## New Hopper Lift Arm Assembly

Assembly part number 100-2-3991

Effectivity date - May 2011



## TRACTOR PTO SHAFT COMPONENTS

(Weasler 55R – Double, Cat. 6, 50 Degree  
Constant Velocity Universal Joint)

<b>Parts List</b>			
<b>Item</b>	<b>Part Number</b>	<b>Description</b>	<b>Qty</b>
1	903-18007	Safety Slide Lock Repair Kit # 26-1520	1
2	903-18008	Safety Slide Lock Yoke Assembly # 55241-1612	1
3	903-18064	Cross and Bearing Kit # 03-10050	4
4	903-18065	Center Housing # 55251-1599	2
5	903-18012	Yoke and Shaft # 99-19545	1
6	903-18066	Nylon Repair Kit # 19-5121	2
7	903-18016	Safety Sing # 13-10021	1
8	903-18067	Outer Guard # 97-22164	1
9	903-18068	Inner Guard # 96-22164	1
10	903-18018	Safety Sign # 13-10022	1
11	903-18019	Yoke, Tube & Slip Sleeve # 98-19545	1
12	903-18023	Ball Shear Assembly # 40-10027	1
13	900-01071	5/16 UNC x 2-1/2 Hex Bolt Grade 5 # 11-10471	1
14	900-06498	5/16 UNC Lock Nut # 11-10044	1

903-18069      PTO Half, Tractor End # 93-22164      1

903-18070      PTO Half, Implement End # 92-22164      1

903-18048      PTO Shaft, Complete # 260-22164      1

## HARDWARE

<b>NUTS</b>		<b>WASHERS</b>	
<b>PART NO.</b>	<b>DESCRIPTION</b>	<b>PART NO.</b>	<b>DESCRIPTION</b>
900-06194	3/16 NC Hex Nut	900-11007	3/16 Lock Washer
900-06001	1/4 NC Hex Nut	900-11009	1/4 Lock Washer
900-06003	5/16 NC Hex Nut	900-11010	5/16 Lock Washer
900-06005	3/8 NC Hex Nut	900-11011	3/8 Lock Washer
900-06007	7/16 NC Hex Nut	900-11012	7/16 Lock Washer
900-06009	1/2 NC Hex Nut	900-11013	1/2 Lock Washer
900-06010	1/2 NF Hex Nut	900-11014	9/16 Lock Washer
900-06011	9/16 NC Hex Nut	900-11015	5/8 Lock Washer
900-06013	5/8 NC Hex Nut	900-11017	3/4 Lock Washer
900-06015	3/4 NC Hex Nut	900-11019	7/8 Lock Washer
900-06017	7/8 NC Hex Nut	900-11021	1" Lock Washer
900-06019	1" NC Hex Nut	900-11023	1-1/8 Lock Washer
900-06023	1-1/4 NC Hex Nut	900-11025	1-1/4 Lock Washer
900-06025	1-3/8 NC Hex Nut	900-11029	1-1/2 Lock Washer
900-06027	1-1/2 NC Hex Nut		
900-06056	5/8 NF Slotted Hex Nut	900-11030	3/16 Flat Washer
900-06058	3/4 NF Slotted Hex Nut	900-11031	1/4 Flat Washer
900-06060	7/8 NF Slotted Hex Nut	900-11032	5/16 Flat Washer
900-06062	1" NF Slotted Hex Nut	900-11033	3/8 Flat Washer
900-06065	1-1/4 NC Slotted Hex Nut	900-11034	7/16 Flat Washer
900-06066	1-1/4 NF Slotted Hex Nut	900-11035	1/2 Flat Washer
900-06070	1-1/2 NF Slotted Hex Nut	900-11036	9/16 Flat Washer
		900-11037	5/8 Flat Washer
900-06135	1/4 NC Flanged Whiz Lock Nut	900-11038	3/4 Flat Washer
900-06137	5/16 NC Flanged Whiz Lock Nut	900-11039	7/8 Flat Washer
900-06139	3/8 NC Flanged Whiz Lock Nut	900-11040	1" Flat Washer
900-06141	7/16 NC Flanged Whiz Lock Nut	900-11041	1-1/8 Flat Washer
900-06143	1/2 NC Flanged Whiz Lock Nut	900-11042	1-1/4 Flat Washer
900-06145	5/8 NC Flanged Whiz Lock Nut	900-11044	1-1/2 Flat Washer
900-06270	3/8 NC Jam Nut		
900-06276	1/2 NC Jam Nut		
900-06280	5/8 NC Jam Nut		
900-06282	3/4 NC Jam Nut		
900-06284	7/8 NC Jam Nut		
900-06286	1" NC Jam Nut		
900-06288	1-1/8 NC Jam Nut		
900-06292	1-3/8 NC Jam Nut		
900-06496	1/4 NC Top Lock Nut		
900-06498	5/16 NC Top Lock Nut		
900-06500	3/8 NC Top Lock Nut		
900-06502	7/16 NC Top Lock Nut		
900-06504	1/2 NC Top Lock Nut		
900-06508	5/8 NC Top Lock Nut		
900-06510	3/4 NC Top Lock Nut		
900-06512	7/8 NC Top Lock Nut		
900-06514	1" NC Top Lock Nut		
900-06518	1-1/4 NC Top Lock Nut		

# INDEX

Part Number	Page
100-2-0955	55
100-2-1801	54
100-2-2657	52
100-2-2680	66
100-2-2709	54
100-2-2709	58
100-2-2747	54
100-2-2760	52
100-2-2798	54
100-2-2800	54
100-2-2800	58
100-2-2801	54
100-2-2804	54
100-2-2806	54
100-2-2807	54
100-2-2818	66
100-2-2819	66
100-2-2822	52
100-2-2824	66
100-2-2843	66
100-2-2843	67
100-2-2874	66
100-2-2874	67
100-2-2925	52
100-2-3064	52
100-2-3067	52
100-2-3069	52
100-2-3077	52
100-2-3078	52
100-2-3079	52
100-2-3089	66
100-2-3126	52
100-2-3128	52
100-2-3131	67
100-2-3247	54

Part Number	Page
100-2-3248	54
100-2-3316	66
100-2-3320	66
100-2-3321	66
100-2-3336	54
100-2-3336	56
100-2-3364	54
100-2-3383	64
100-2-3420	64
100-2-3511	52
100-2-3512	64
100-2-3513	64
100-2-3517	64
100-2-3521	64
100-2-3525	64
100-2-3528	64
100-2-3529	64
100-2-3534	66
100-2-3535	66
100-2-3536	54
100-2-3539	66
100-2-3540	66
100-2-3541	66
100-2-3542	66
100-2-3543	66
100-2-3544	66
100-2-3555	66
100-2-3559	66
100-2-3560	66
100-2-3564	66
100-2-3566	54
100-2-3568	54
100-2-3571	66
100-2-3574	66
100-2-3575	54

Part Number	Page
100-2-3575	54
100-2-3576	54
100-2-3577	54
100-2-3578	66
100-2-3579	66
100-2-3580	66
100-2-3583	66
100-2-3584	54
100-2-3585	54
100-2-3586	54
100-2-3587	54
100-2-3588	54
100-2-3597	54
100-2-3604	67
100-2-3605	67
100-2-3608	64
100-2-3609	64
100-2-3610	64
100-2-3611	64
100-2-3612	64
100-2-3613	64
100-2-3614	64
100-2-3615	64
100-2-3616	64
100-2-3617	64
100-2-3618	64
100-2-3619	64
100-2-3638	66
100-2-3705	60
100-2-3971	58
100-2-3991	67
100-2-4000	55
100-2-4000	56
100-2-4000	59
100-2-4001	60

# INDEX

Part Number	Page
100-2-4002	60
100-2-4026	58
100-2-4028	55
100-2-4028	56
100-2-4028	61
100-2-4029	62
100-2-4030	62
100-2-4033	62
100-2-4035	56
100-2-4041	52
100-2-4042	55
100-2-4042	56
100-2-4042	57
100-2-4042	58
100-2-4043	58
100-2-4044	58
100-2-4045	58
100-2-4046	58
100-2-4048	56
100-3-1113	54
100-3-1113	60
100-3-1113	66
100-3-2485	56
100-3-3292	54
100-3-3510	54
100-3-3675	54
100-3-3675	58
100-3-3864	66
100-3-4000	54
100-3-4109	54
100-3-4208	66
100-3-4209	66
100-3-4278	52
100-3-4282	52
100-3-4283	52

Part Number	Page
100-3-4287	52
100-3-4287	52
100-3-4291	52
100-3-4334	54
100-3-4371	54
100-3-4465	54
100-3-4467	54
100-3-4468	54
100-3-4468	58
100-3-4662	66
100-3-4747	66
100-3-4747	67
100-3-4826	52
100-3-4831	52
100-3-4838	52
100-3-4841	52
100-3-4844	52
100-3-4844	54
100-3-4846	66
100-3-4933	52
100-3-4938	66
100-3-4942	54
100-3-4942	58
100-3-5255	52
100-3-5258	66
100-3-5258	67
100-3-5340	54
100-3-5340	58
100-3-5341	54
100-3-5341	58
100-3-5377	66
100-3-5512	54
100-3-5514	54
100-3-5514	62
100-3-5555	64

Part Number	Page
100-3-5744	64
100-3-5754	64
100-3-5831	52
100-3-5839	54
100-3-5856	66
100-3-5865	54
100-3-5873	54
100-3-5874	54
100-3-5882	54
100-3-5886	54
100-3-5887	54
100-3-5889	52
100-3-5890	52
100-3-5891	54
100-3-5896	52
100-3-5897	52
100-3-5899	54
100-3-5903	64
100-3-5945	67
100-3-5946	67
100-3-5949	67
100-3-5970	64
100-3-6190	58
100-3-6300	58
100-3-6305	56
100-3-6344	62
100-3-6364	58
100-3-6365	58
100-3-6369	60
100-3-6374	58
100-5-1217	56
100-5-1221	60
100-5-1222	56
106-2-0710	54
106-2-0710	66

# INDEX

Part Number	Page
106-2-0711	54
106-2-0711	66
106-2-0712	66
200-2-0705	52
900-01053	58
900-01055	52
900-01055	54
900-01055	54
900-01055	66
900-01059	54
900-01063	66
900-01071	68
900-01075	62
900-01105	52
900-01113	66
900-01121	54
900-01121	56
900-01129	54
900-01129	58
900-01141	54
900-01221	54
900-01221	58
900-01221	66
900-01223	62
900-01225	52
900-01229	52
900-01233	54
900-01233	66
900-01237	66
900-01241	54
900-01241	56
900-01241	60
900-01241	64
900-01241	67
900-01249	52

Part Number	Page
900-01337	66
900-01339	52
900-01339	56
900-01341	66
900-01341	66
900-01343	52
900-01345	58
900-01345	66
900-01349	52
900-01353	67
900-01357	67
900-01361	66
900-01363	66
900-01403	64
900-01403	64
900-01403	64
900-01407	54
900-01407	56
900-01411	52
900-01423	54
900-01423	58
900-01423	64
900-01423	64
900-01425	64
900-01429	64
900-01475	64
900-01481	64
900-01535	64
900-01630	64
900-01632	64
900-01694	54
900-03419	54
900-03419	62
900-03436	52
900-03436	54

Part Number	Page
900-03436	58
900-03436	60
900-03436	62
900-03438	52
900-03438	54
900-03438	54
900-03438	58
900-03439	52
900-03439	54
900-03439	54
900-03439	58
900-03439	60
900-03439	66
900-06001	69
900-06003	69
900-06005	69
900-06007	69
900-06009	69
900-06010	69
900-06011	69
900-06013	69
900-06015	69
900-06017	69
900-06019	69
900-06023	69
900-06025	69
900-06027	69
900-06056	69
900-06058	69
900-06060	69
900-06062	69
900-06065	69
900-06066	69
900-06070	69
900-06135	69

## INDEX

Part Number	Page
900-06137	52
900-06137	54
900-06137	54
900-06137	54
900-06137	62
900-06137	66
900-06137	69
900-06139	52
900-06139	54
900-06139	54
900-06139	54
900-06139	54
900-06139	58
900-06139	60
900-06139	66
900-06139	66
900-06139	69
900-06141	69
900-06143	52
900-06143	54
900-06143	64
900-06143	66
900-06143	67
900-06143	69
900-06145	52
900-06145	56
900-06145	58
900-06145	66
900-06145	67
900-06145	69
900-06147	64
900-06147	64
900-06147	64
900-06194	69
900-06270	69

Part Number	Page
900-06276	69
900-06280	69
900-06282	69
900-06284	69
900-06286	69
900-06288	69
900-06292	69
900-06496	69
900-06498	62
900-06498	68
900-06498	69
900-06500	54
900-06500	56
900-06500	58
900-06500	69
900-06502	69
900-06504	52
900-06504	54
900-06504	54
900-06504	56
900-06504	58
900-06504	60
900-06504	64
900-06504	69
900-06508	66
900-06508	69
900-06510	52
900-06510	54
900-06510	54
900-06510	56
900-06510	69
900-06512	69
900-06514	69
900-06518	69
900-06578	62

Part Number	Page
900-06596	64
900-06598	64
900-06604	64
900-11007	69
900-11009	69
900-11010	69
900-11011	69
900-11012	69
900-11013	54
900-11013	62
900-11013	69
900-11014	69
900-11015	69
900-11017	69
900-11019	69
900-11021	69
900-11023	69
900-11025	69
900-11029	69
900-11030	69
900-11031	69
900-11032	69
900-11033	54
900-11033	58
900-11033	69
900-11034	69
900-11035	52
900-11035	69
900-11036	69
900-11037	58
900-11037	69
900-11038	64
900-11038	69
900-11039	64
900-11039	69



# INDEX

Part Number	Page
900-11040	69
900-11041	69
900-11042	69
900-11044	64
900-11044	69
900-11129	54
900-11129	66
900-16361	54
900-17602	62
900-23023	52
900-25005	67
900-27024	54
900-29082	54
900-31082	64
901-01079	54
901-01079	66
901-01101	54
901-01301	52
901-01311	52
901-01313	52
901-01357	58
901-09220	52
903-15633	54
903-15633	62
903-15634	52
903-18007	68
903-18008	68
903-18012	68
903-18016	68
903-18018	68
903-18019	68
903-18023	68
903-18048	52
903-18048	68
903-18064	68

Part Number	Page
903-18065	68
903-18066	68
903-18067	68
903-18068	68
903-18069	68
903-18070	68
905-01159	54
905-03080	54
905-09004	64
905-09079	64
905-09134	54
905-09134	58
905-21224	64
905-23024	52

Part Number	Page
-------------	------





**701 Lenham Ave. - P.O. Box 647**

**Cooperstown, ND 58425**

**Office (701) 797-2700**

**Fax (701) 797-2584**

**Toll Free (800) 797-1883**

**[www.sheyennemfg.com](http://www.sheyennemfg.com)**